

MINI ROK 2025

SCHEDA D'IDENTIFICAZIONE

IDENTIFICATION SHEET

FICHE D'IDENTIFICATION

La presente scheda di identificazione riproduce descrizioni, illustrazioni e dimensioni del motore **MINI ROK**.
 This Identification Sheet reproduces descriptions, illustrations and dimensions of the **MINI ROK**.
 La présente Fiche d'Identification reproduit descriptions, illustrations et dimensions du moteur **MINI ROK**.

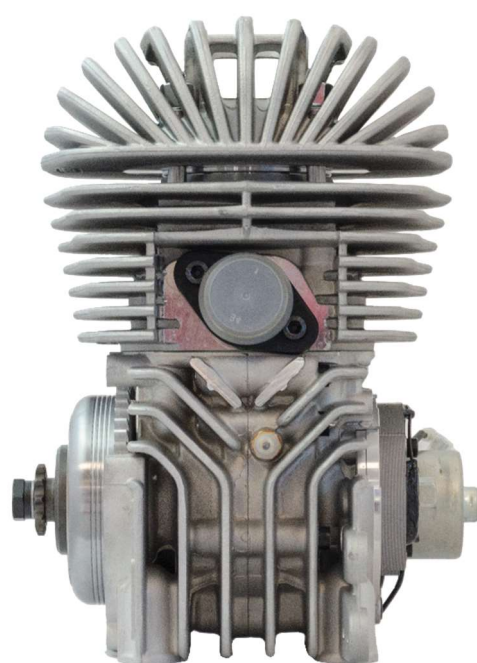
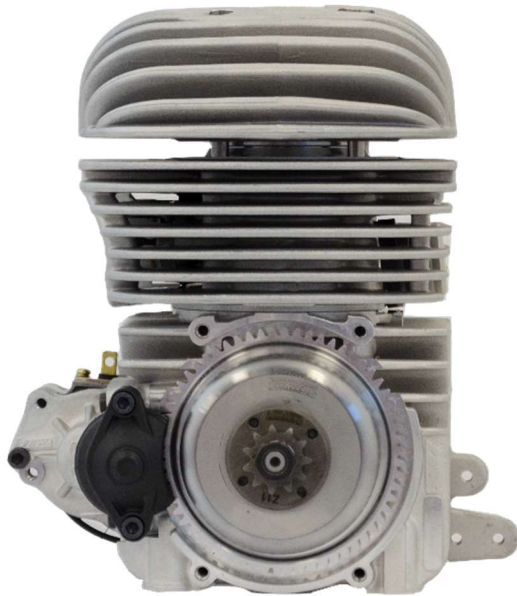

TUTTI LE PARTI DEL MOTORE DEVONO ESSERE ORIGINALI VORTEX ROK.

Né il motore né gli accessori possono essere in alcun modo modificati, per modifica si intende qualsiasi cambiamento di forma, contenuto o funzione, che rappresenti una condizione di differenza da quanto originariamente costruito (prodotto ed assemblato), inclusa l'aggiunta e/o l'asportazione di materiale. Tutte le misure dimensionali nei disegni tecnici si intendono in mm.

ALL THE ENGINE PARTS MUST BE ORIGINAL BY VORTEX ROK.

Neither engines nor accessories can be modified. By this we mean any shape, content or function changes which may differ from what originally produced (manufactured and assembled). Furthermore this includes any addition and /or removal of material.

All dimensions in the technical drawings are in mm.

TOUTES LES PARTIES DU MOTEUR DOIVENT ETRE ORIGINALES VORTEX ROK.

Ni le moteur ni les accessoires peuvent être modifiés, qu'il s'agisse d'un changement de forme, de contenu ou de fonctionnement, représentant une condition de différence par rapport à sa construction d'origine (produit et assemblé), ci-inclus aussi l'addition et/ou l'enlèvement de matériaux. Toutes les cotes dans les dessins techniques sont en mm.

ATTENTION



MINI ROK 2025

INFORMAZIONI DI BASE E CARATTERISTICHE TECNICHE TECHNICAL INFORMATION AND CHARACTERISTICS INFORMATION DE BASE ET CARACTÉRISTIQUES TECHNIQUES			
ALESAGGIO ORIGINALE	ORIGINAL BORE	ALESAGE D'ORIGINE	41,96 mm
ALESAGGIO MASSIMO	MAX ALLOWED BORE	ALESAGE MAXIMUM	42.10 mm
CORSA	STROKE	COURSE	43 +/- 0,1 mm
CILINDRATA ORIGINALE	ORIGINAL DISPLACEMENT	CAPACITE' D'ORIGINE	60 cc
INTERASSE BIELLA	CONROD C-TO-C DISTANCE	ENTRAXE DE LE BIELLE	90 +/- 0,1 mm
PESO DELLA BIELLA	WEIGHT OF CONROD	POIDS DE LA BIELLE	94g +/- 2g
PIGNONE	SPROCKET	PIGNON	Z10-Z11-Z12
SVILUPPO DEL CILINDRO E DISTRIBUZIONE CYLINDER DEVELOPEMENT AND DISTRIBUTION DEVELOPPEMENT DU CYLINDRE ET DISTRIBUTION			
SCARICO	EXHAUST PORT	ECHAPPEMENT	154° +/- 2° (US)
TRAVASI PRINCIPALI	MAIN TRANSFER	TRANSFERES PRINCIPAL	116° ±1.5°
AMMISSIONE	ADMISSION	ADMISSION	143° ±1.5°
<p><u>Controllo della distribuzione come descritto nel Regolamento Tecnico del Trofeo di Marca ROK CUP USA 2024.</u> <u>Check of the distribution as described in the ROK CUP USA 2024 Technical Regulation.</u> <u>Contrôle de la distribution tel que décrit dans le Règlement Technique du trophée de la marque ROK CUP USA 2024.</u></p> <p><u>Il controllo deve essere effettuato a testa smontata (coppia di serraggio prigionieri: 1.8 kgm).</u> <u>Measurement must be done with engine head dismantled (studs tightening torque: 1.8 kgm).</u> <u>Le contrôle doit être effectué avec la tête démontée (couple de serrage des goujons: 1.8 kgm).</u></p>			

ATTENTION

TUTTI LE PARTI DEL MOTORE DEVONO ESSERE ORIGINALI VORTEX ROK.

Né il motore né gli accessori possono essere in alcun modo modificati, per modifica si intende qualsiasi cambiamento di forma, contenuto o funzione, che rappresenti una condizione di differenza da quanto originariamente costruito (prodotto ed assemblato), inclusa l'aggiunta e/o l'asportazione di materiale. Tutte le misure dimensionali nei disegni tecnici si intendono in mm.

ALL THE ENGINE PARTS MUST BE ORIGINAL BY VORTEX ROK.





Neither engines nor accessories can be modified. By this we mean any shape, content or function changes which may differ from what originally produced (manufactured and assembled). Furthermore this includes any addition and /or removal of material.

All dimensions in the technical drawings are in mm.

TOUTES LES PARTIES DU MOTEUR DOIVENT ETRE ORIGINALES VORTEX ROK.

Ni le moteur ni les accessoires peuvent être modifiés, qu'il s'agisse d'un changement de forme, de contenu ou de fonctionnement, représentant une condition de différence par rapport à sa construction d'origine (produit et assemblé), ci-inclus aussi l'addition et/ou l'enlèvement de matériaux. Toutes les cotes dans les dessins techniques sont en mm.

MINI ROK 2025

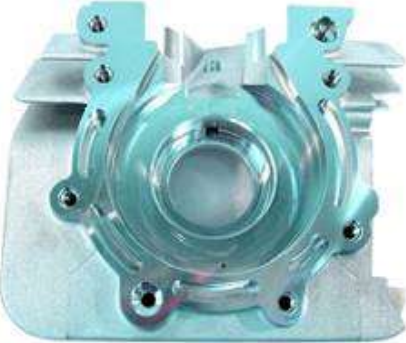
<p>FOTO DEL MOTORE LATO SUPERIORE PICTURE ENGINE UPPER SIDE PHOTO MOTEUR VUE SUPERIOR</p>	<p>FOTO DEL MOTORE LATO INFERIORE PICTURE ENGINE LOWER SIDE PHOTO MOTEUR VUE INFERIOR</p>
	
<p>BASE CILINDRO CYLINDER BASE PIED DU CYLINDRE</p>	<p>TESTA E CAMERA DI COMBUSTIONE CYLINDERHEAD AND COMBUSTION CHAMBER CULASSE ET CHAMBRE DE COMBUSTION</p>
	
<p>FOTO DEI CARTER PICTURE OF THE CRANKCASE PHOTO DU CARTER</p>	<p>FOTO INTERNA DEL CARTER INTERIOR PICTURE OF THE CRANKCASE PHOTO ENTERIEUR DU CARTER</p>
	

<p>ATTENTION</p>	<p><u>TUTTI LE PARTI DEL MOTORE DEVONO ESSERE ORIGINALI VORTEX ROK.</u> Né il motore né gli accessori possono essere in alcun modo modificati, per modifica si intende qualsiasi cambiamento di forma, contenuto o funzione, che rappresenti una condizione di differenza da quanto originariamente costruito (prodotto ed assemblato), inclusa l'aggiunta e/o l'asportazione di materiale. Tutte le misure dimensionali nei disegni tecnici si intendono in mm.</p> <p><u>ALL THE ENGINE PARTS MUST BE ORIGINAL BY VORTEX ROK.</u> Neither engines nor accessories can be modified. By this we mean any shape, content or function changes which may differ from what originally produced (manufactured and assembled). Furthermore this includes any addition and /or removal of material. All dimensions in the technical drawings are in mm.</p> <p><u>TOUTES LES PARTIES DU MOTEUR DOIVENT ETRE ORIGINALES VORTEX ROK.</u> Ni le moteur ni les accessoires peuvent être modifiés, qu'il s'agisse d'un changement de forme, de contenu ou de fonctionnement, représentant une condition de différence par rapport à sa construction d'origine (produit et assemblé), ci-inclus aussi l'addition et/ou l'enlèvement de matériaux. Toutes les cotes dans les dessins techniques sont en mm.</p>
-------------------------	--

MINI ROK 2025

SEZIONE DEL CILINDRO CYLINDER SECTION COUPE PAR SECTION DU CYLINDRE

DISTANZA MINIMA DEL PIANO APPOGGIO CARBURATORE DALL' ASSE DEL CILINDRO
MINIMUM DISTANCE OF THE CARBURETTOR SUPPORTING PLATE FROM THE CYLINDER AXLE
DISTANCE MINIMAL DU SOL DU CARBURATEUR OU CYLINDRE

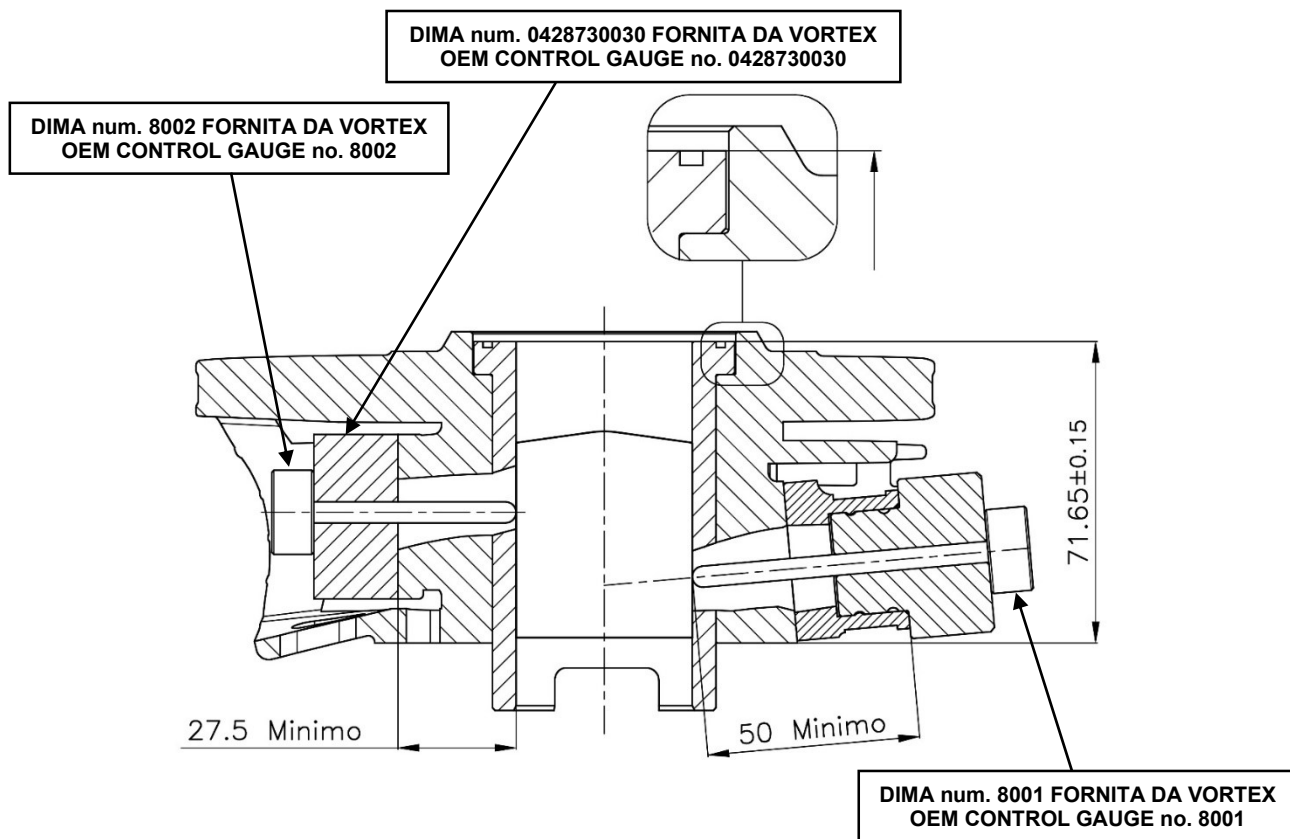

GUARNIZIONE SCARICO EXHAUST GASKET POT D'ÉCHAPEMENT

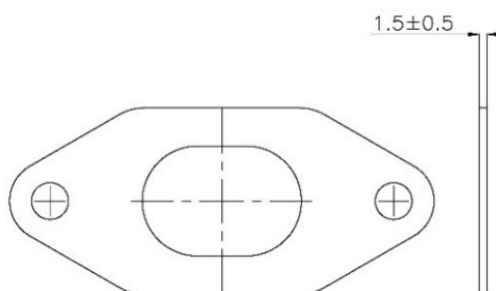

ATTENTION

TUTTI LE PARTI DEL MOTORE DEVONO ESSERE ORIGINALI VORTEX ROK.

Né il motore né gli accessori possono essere in alcun modo modificati, per modifica si intende qualsiasi cambiamento di forma, contenuto o funzione, che rappresenti una condizione di differenza da quanto originariamente costruito (prodotto ed assemblato), inclusa l'aggiunta e/o l'asportazione di materiale. Tutte le misure dimensionali nei disegni tecnici si intendono in mm.

ALL THE ENGINE PARTS MUST BE ORIGINAL BY VORTEX ROK.

Neither engines nor accessories can be modified. By this we mean any shape, content or function changes which may differ from what originally produced (manufactured and assembled). Furthermore this includes any addition and /or removal of material.

All dimensions in the technical drawings are in mm.

TOUTES LES PARTIES DU MOTEUR DOIVENT ÊTRE ORIGINALES VORTEX ROK.

Ni le moteur ni les accessoires peuvent être modifiés, qu'il s'agisse d'un changement de forme, de contenu ou de fonctionnement, représentant une condition de différence par rapport à sa construction d'origine (produit et assemblé), ci-inclus aussi l'addition et/ou l'enlèvement de matériaux. Toutes les cotes dans les dessins techniques sont en mm.

MINI ROK 2025

PISTONE
PISTON
PISTON

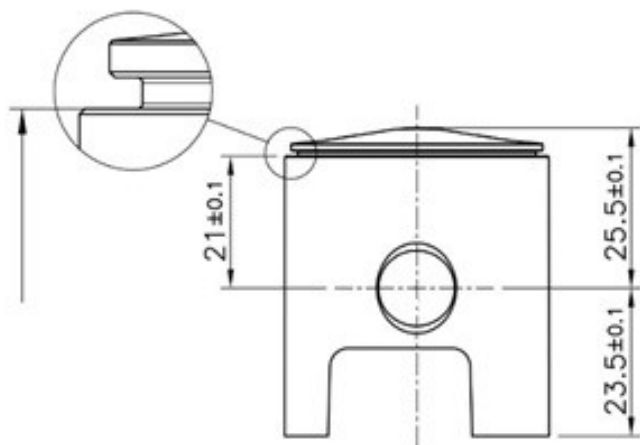

PESO – WEIGHT - POIDS
59 gr +/- 5 gr

SPINOTTO PISTONE
PISTON PIN
AXE DE PISTON

DETTAGLIO SEGMENTO PISTONE
PISTON RING DETAIL PIECE
DETAILLE DU SEGMENT DE PISTON

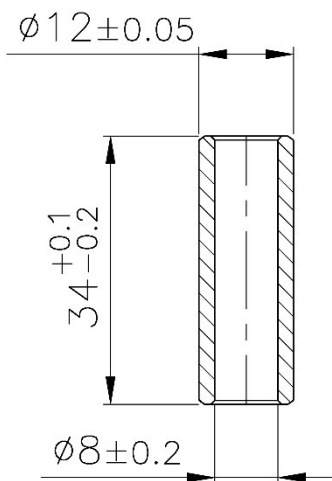

PESO – WEIGHT - POIDS
15 gr Min

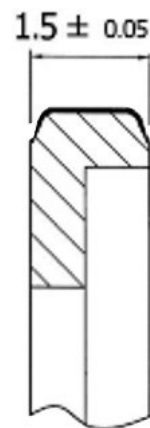

ATTENTION

TUTTI LE PARTI DEL MOTORE DEVONO ESSERE ORIGINALI VORTEX ROK.

Né il motore né gli accessori possono essere in alcun modo modificati, per modifica si intende qualsiasi cambiamento di forma, contenuto o funzione, che rappresenti una condizione di differenza da quanto originariamente costruito (prodotto ed assemblato), inclusa l'aggiunta e/o l'asportazione di materiale. Tutte le misure dimensionali nei disegni tecnici si intendono in mm.

ALL THE ENGINE PARTS MUST BE ORIGINAL BY VORTEX ROK.

Neither engines nor accessories can be modified. By this we mean any shape, content or function changes which may differ from what originally produced (manufactured and assembled). Furthermore this includes any addition and /or removal of material.

All dimensions in the technical drawings are in mm.

TOUTES LES PARTIES DU MOTEUR DOIVENT ETRE ORIGINALES VORTEX ROK.

Ni le moteur ni les accessoires peuvent être modifiés, qu'il s'agisse d'un changement de forme, de contenu ou de fonctionnement, représentant une condition de différence par rapport à sa construction d'origine (produit et assemblé), ci-inclus aussi l'addition et/ou l'enlèvement de matériaux. Toutes les cotes dans les dessins techniques sont en mm.

MINI ROK 2025

FOTO E MARCHIATURA DEL PISTONE
 PICTURE AND MARKING OF THE PISTON
 PHOTO ET MARQUAGE DU PISTON

Obbligatorio avere il pistone marchiato VORTEX in fusione come da figura.
 Mandatory to have the brand VORTEX cast piston as shown in the picture.
 Obligatoire d'avoir le piston en fonte marque VORTEX comme sur la figure.

Obbligatorio avere il numero di CONCHIGLIA marchiato come da figura.
 Mandatory to have the number of the mold cast as shown in the picture.
 Il est obligatoire d'avoir le numéro de moule marqué comme indiqué sur la figure.

OPTION 1



OPTION 1



OPTION 2



OPTION 2



ATTENTION

TUTTI LE PARTI DEL MOTORE DEVONO ESSERE ORIGINALI VORTEX ROK.

Né il motore né gli accessori possono essere in alcun modo modificati, per modifica si intende qualsiasi cambiamento di forma, contenuto o funzione, che rappresenti una condizione di differenza da quanto originariamente costruito (prodotto ed assemblato), inclusa l'aggiunta e/o l'asportazione di materiale. Tutte le misure dimensionali nei disegni tecnici si intendono in mm.

ALL THE ENGINE PARTS MUST BE ORIGINAL BY VORTEX ROK.

Neither engines nor accessories can be modified. By this we mean any shape, content or function changes which may differ from what originally produced (manufactured and assembled). Furthermore this includes any addition and /or removal of material.

All dimensions in the technical drawings are in mm.

TOUTES LES PARTIES DU MOTEUR DOIVENT ETRE ORIGINALES VORTEX ROK.

Ni le moteur ni les accessoires peuvent être modifiés, qu'il s'agisse d'un changement de forme, de contenu ou de fonctionnement, représentant une condition de différence par rapport à sa construction d'origine (produit et assemblé), ci-inclus aussi l'addition et/ou l'enlèvement de matériaux. Toutes les cotes dans les dessins techniques sont en mm.

MINI ROK 2025

**DISEGNO DELLA TESTA E CAMERA DI COMBUSTIONE
DRAWING OF CYLINDERHEAD AND COMBUSTION CHAMBER
DISSIN DU CULASSE ET CHAMBRE DE COMBUSTION**

Average taken from both sides of the piston, using Rotax 2.0mm solder 100g #9735

SQUISH THICKNESS – SQUISH - EPESSEUR DE SQUISH: 0.75mm MIN

**DIMA CONTROLLO PROFILO CAMERA DI COMBUSTIONE
TEMPLATE FOR CHECKING THE COMBUSTION
CHAMBER PROFILE
GABARIT POUR LA VERIFICATION DU PROFIL DE LA
CHAMBRE DE COMBUSTION**

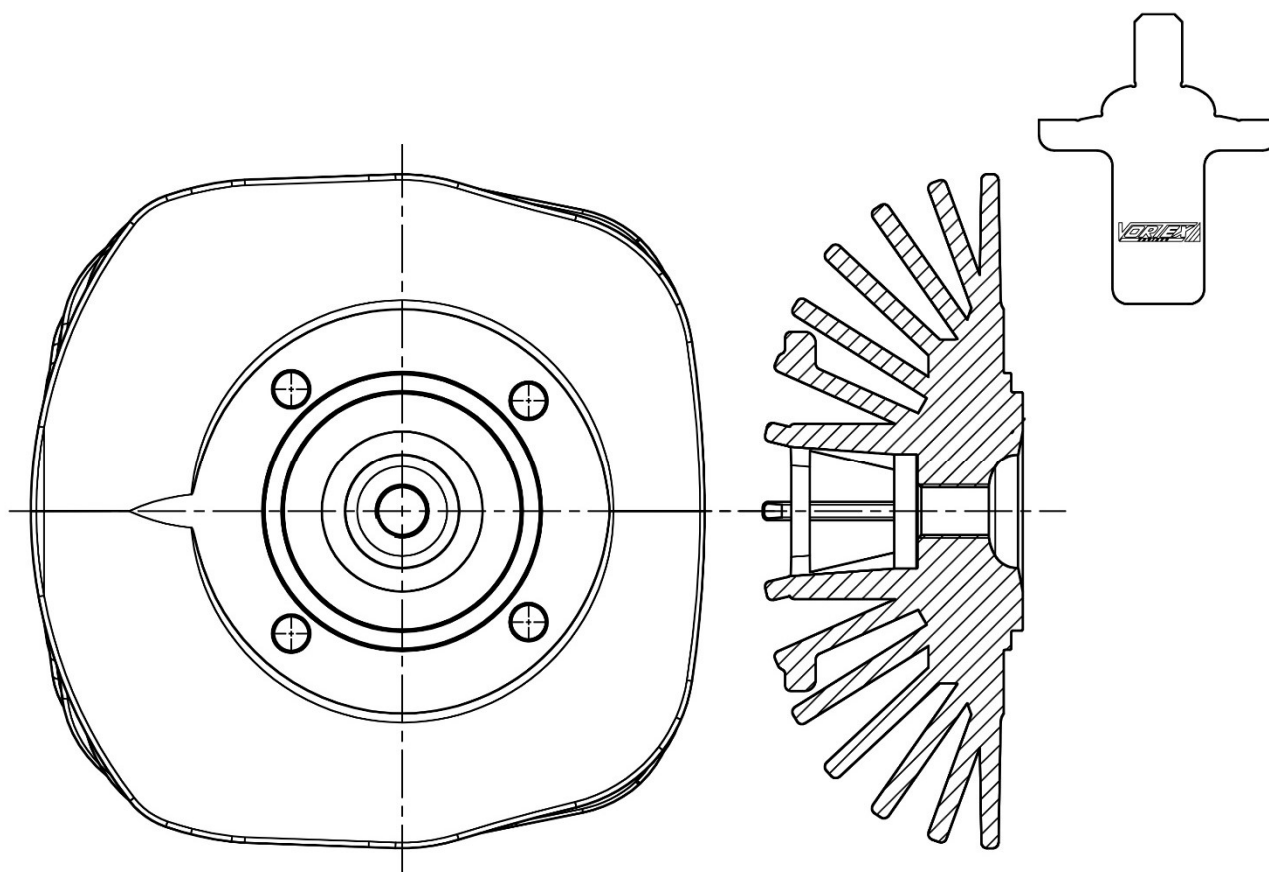

ATTENTION

TUTTI LE PARTI DEL MOTORE DEVONO ESSERE ORIGINALI VORTEX ROK.

Né il motore né gli accessori possono essere in alcun modo modificati, per modifica si intende qualsiasi cambiamento di forma, contenuto o funzione, che rappresenti una condizione di differenza da quanto originariamente costruito (prodotto ed assemblato), inclusa l'aggiunta e/o l'asportazione di materiale. Tutte le misure dimensionali nei disegni tecnici si intendono in mm.

ALL THE ENGINE PARTS MUST BE ORIGINAL BY VORTEX ROK.

Neither engines nor accessories can be modified. By this we mean any shape, content or function changes which may differ from what originally produced (manufactured and assembled). Furthermore this includes any addition and /or removal of material.

All dimensions in the technical drawings are in mm.

TOUTES LES PARTIES DU MOTEUR DOIVENT ETRE ORIGINALES VORTEX ROK.

Ni le moteur ni les accessoires peuvent être modifiés, qu'il s'agisse d'un changement de forme, de contenu ou de fonctionnement, représentant une condition de différence par rapport à sa construction d'origine (produit et assemblé), ci-inclus aussi l'addition et/ou l'enlèvement de matériaux. Toutes les cotes dans les dessins techniques sont en mm.

MINI ROK 2025

ALBERO MOTORE E ASSE D'ACCOPIAMENTO CRANKSHAFT AND CRANKPIN VILEBREQUIN ET AXE DE VILLEBREQUIN

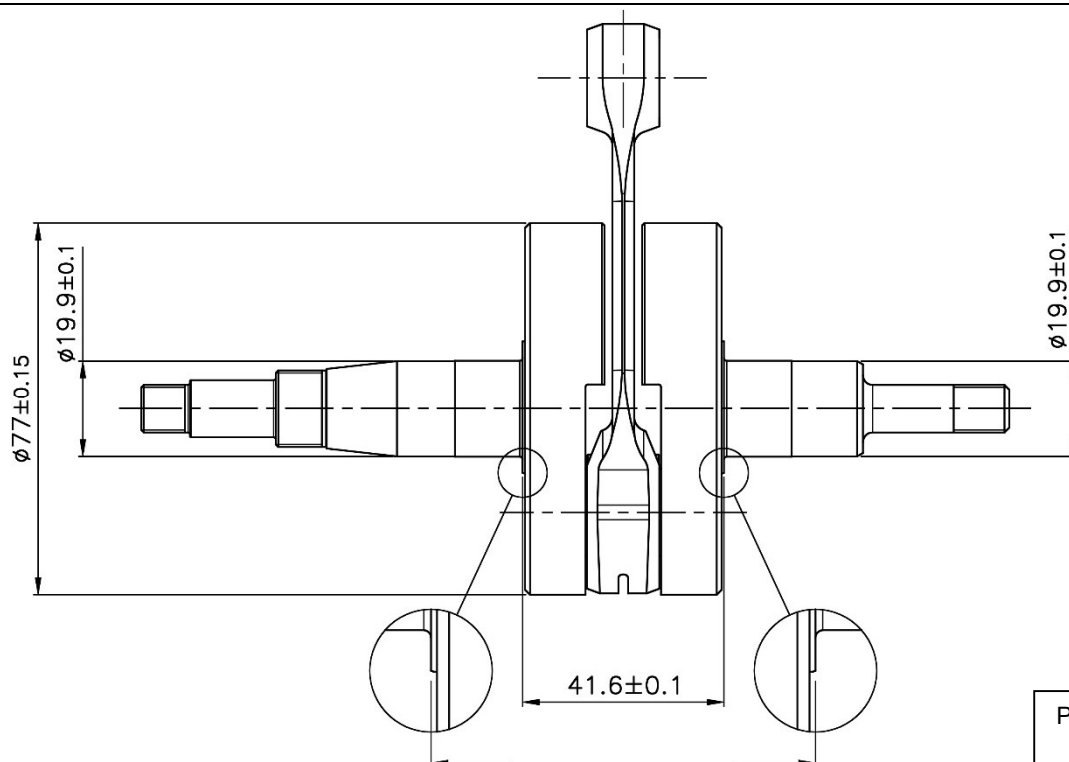

Peso – Weight – Poids
1.312g +/- 10g

ASSE DI ACCOPIAMENTO CRANK PIN AXE DE FIXATION

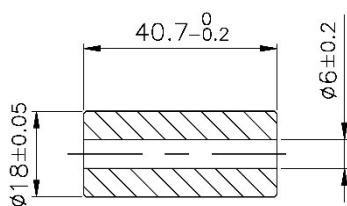

Peso – Weight – Poids
71g +/- 1g

OPTION 1



OPTION 2



ATTENTION

TUTTI LE PARTI DEL MOTORE DEVONO ESSERE ORIGINALI VORTEX ROK.

Né il motore né gli accessori possono essere in alcun modo modificati, per modifica si intende qualsiasi cambiamento di forma, contenuto o funzione, che rappresenti una condizione di differenza da quanto originariamente costruito (prodotto ed assemblato), inclusa l'aggiunta e/o l'asportazione di materiale. Tutte le misure dimensionali nei disegni tecnici si intendono in mm.

ALL THE ENGINE PARTS MUST BE ORIGINAL BY VORTEX ROK.

Neither engines nor accessories can be modified. By this we mean any shape, content or function changes which may differ from what originally produced (manufactured and assembled). Furthermore this includes any addition and /or removal of material.

All dimensions in the technical drawings are in mm.

TOUTES LES PARTIES DU MOTEUR DOIVENT ETRE ORIGINALES VORTEX ROK.

Ni le moteur ni les accessoires peuvent être modifiés, qu'il s'agisse d'un changement de forme, de contenu ou de fonctionnement, représentant une condition de différence par rapport à sa construction d'origine (produit et assemblé), ci-inclus aussi l'addition et/ou l'enlèvement de matériaux. Toutes les cotes dans les dessins techniques sont en mm.

MINI ROK 2025

FOTO E TIMBRATURA DELLA BIELLA
 PICTURES AND MARKING OF CONROD
 PHOTO ET MARQUAGE DE LA BIELLE COUTE DROITE



FOTO DELL'ALBERO MOTORE EVIDENZIANDO MASSE PER EQUILIBRATURA
 PICTURE OF CRANKSHAFT WITH THE BALANCER
 PHOTO DE VILEBREQUIN



TUTTI LE PARTI DEL MOTORE DEVONO ESSERE ORIGINALI VORTEX ROK.

Né il motore né gli accessori possono essere in alcun modo modificati, per modifica si intende qualsiasi cambiamento di forma, contenuto o funzione, che rappresenti una condizione di differenza da quanto originariamente costruito (prodotto ed assemblato), inclusa l'aggiunta e/o l'asportazione di materiale. Tutte le misure dimensionali nei disegni tecnici si intendono in mm.

ALL THE ENGINE PARTS MUST BE ORIGINAL BY VORTEX ROK.

Neither engines nor accessories can be modified. By this we mean any shape, content or function changes which may differ from what originally produced (manufactured and assembled). Furthermore this includes any addition and /or removal of material.

All dimensions in the technical drawings are in mm.

TOUTES LES PARTIES DU MOTEUR DOIVENT ETRE ORIGINALES VORTEX ROK.

Ni le moteur ni les accessoires peuvent être modifiés, qu'il s'agisse d'un changement de forme, de contenu ou de fonctionnement, représentant une condition de différence par rapport à sa construction d'origine (produit et assemblé), ci-inclus aussi l'addition et/ou l'enlèvement de matériaux. Toutes les cotes dans les dessins techniques sont en mm.

ATTENTION

MINI ROK 2025

VISTA INTERNA DEL CARTER E VISTA DI ASSIEME
 INTERIOR VIEW OF THE CRANKCASE AND ASSEMBLY VIEW
 VUE DE LA PARTIE INTERIEURE DU CARTER ET DESSIN D'ASSEMBLAGE

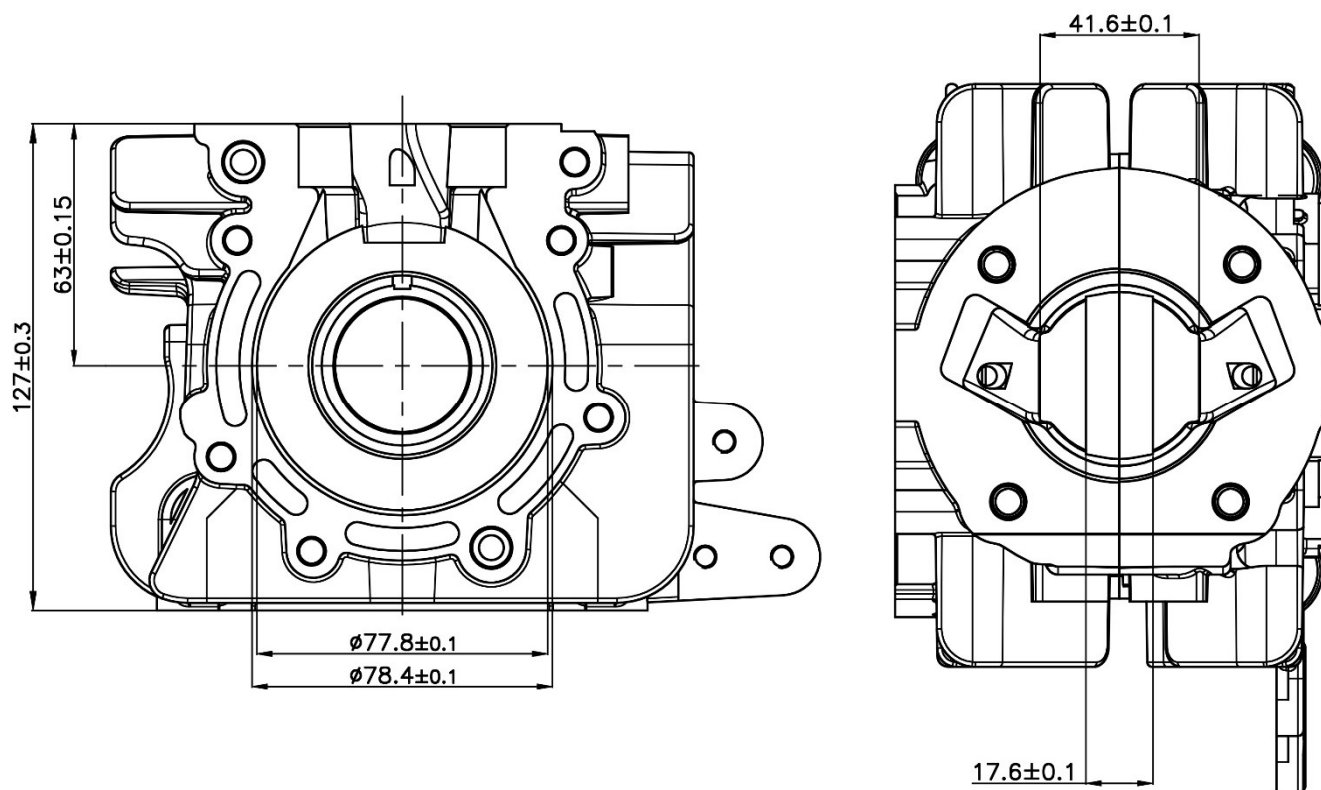

CUSCINETTI ALBERO MOTORE
 CRANKSHAFT BEARINGS
 PALIERS DE VILEBREQUIN

TIPO TYPE TIPE	DIMENSIONI DIMENSION DIMENSIONS	CARATTERISTICHE CHARACTERISTICS CARACTÉRISTIQUES
Marca libera/Free brand/ Marque libre 6204.C4	20x47x14mm	Sfere In Acciaio/ Steel Balls/ Billes D'acier 8

ATTENTION

TUTTI LE PARTI DEL MOTORE DEVONO ESSERE ORIGINALI VORTEX ROK.

Né il motore né gli accessori possono essere in alcun modo modificati, per modifica si intende qualsiasi cambiamento di forma, contenuto o funzione, che rappresenti una condizione di differenza da quanto originariamente costruito (prodotto ed assemblato), inclusa l'aggiunta e/o l'asportazione di materiale. Tutte le misure dimensionali nei disegni tecnici si intendono in mm.

ALL THE ENGINE PARTS MUST BE ORIGINAL BY VORTEX ROK.

Neither engines nor accessories can be modified. By this we mean any shape, content or function changes which may differ from what originally produced (manufactured and assembled). Furthermore this includes any addition and /or removal of material.

All dimensions in the technical drawings are in mm.

TOUTES LES PARTIES DU MOTEUR DOIVENT ETRE ORIGINALES VORTEX ROK.

Ni le moteur ni les accessoires peuvent être modifiés, qu'il s'agisse d'un changement de forme, de contenu ou de fonctionnement, représentant une condition de différence par rapport à sa construction d'origine (produit et assemblé), ci-inclus aussi l'addition et/ou l'enlèvement de matériaux. Toutes les cotes dans les dessins techniques sont en mm.

MINI ROK 2025

FOTO DEL DETTAGLIO DELLA POSIZIONE PARAOLIO ALBERO MOTORE
 DETAIL PHOTO OF THE CRANKSHAFT OIL SEAL POSITION
 PHOTO DE DÉTAIL DE LA POSITION DU JOINT D'HUILE DU VILEBREQUIN



ROTORE FRIZIONE COMPLETO CON INGRANAGGIO AVVIAMENTO
 COMPL. CLUTCH ROTOR WITH STARTING GEAR
 ROTOR EMBRAYAGE AVEC VITESSE DE DEMARRAGE

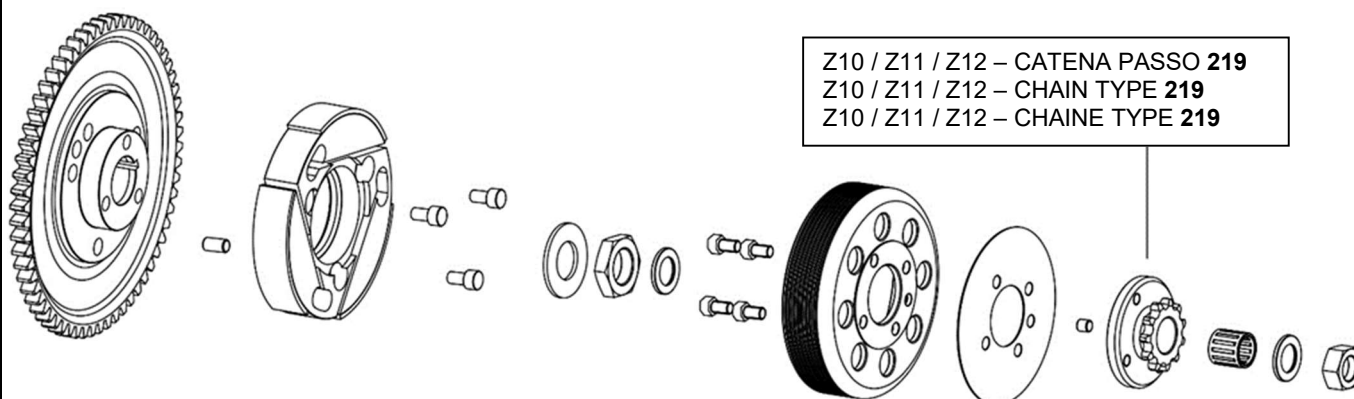

Z10 / Z11 / Z12 – CATENA PASSO 219
 Z10 / Z11 / Z12 – CHAIN TYPE 219
 Z10 / Z11 / Z12 – CHAÎNE TYPE 219

NUMERO DI PARTI: 20
 PARTS QUANTITY: 20
 NOMBRE DE PIÈCES COMPOSANTES: 20

PESO DELLA FRIZIONE COMPLETA DI INGRANAGGIO AVVIAMENTO E PROTEZIONE: **855 gr +/- 15gr** **855 gr +/- 30gr**
 WEIGHT OF THE COMPLETE CLUTCH WITH STARTING GEAR AND PROTECTION: **855 gr +/- 15gr** **855 gr +/- 30gr**
 POIDS DE L'EMBRAYAGE COMPLETE AVEC ENGRENAGE DEMARAGE ET PROTECTION: **855 gr +/- 15gr** **855 gr +/- 30gr**

REGIME DI ATTACCO (MASSIMO) VERIFICABILE IN OGNI MOMENTO DELLA MANIFESTAZIONE: **3500RPM**
 ENGAGEMENT SPEED (MAXIMUM) CAN BE VERIFIED IN EVERY MOMENT OF THE EVENT: **3500RPM**
 VITESSE DE ENTRAINEMENT (MAXIMUM) VERIFIABLE DANS TOUS LES MOMENTS DE LA MANIFESTATION: **3500RPM**

TUTTI LE PARTI DEL MOTORE DEVONO ESSERE ORIGINALI VORTEX ROK.

Né il motore né gli accessori possono essere in alcun modo modificati, per modifica si intende qualsiasi cambiamento di forma, contenuto o funzione, che rappresenti una condizione di differenza da quanto originariamente costruito (prodotto ed assemblato), inclusa l'aggiunta e/o l'asportazione di materiale. Tutte le misure dimensionali nei disegni tecnici si intendono in mm.

ALL THE ENGINE PARTS MUST BE ORIGINAL BY VORTEX ROK.

Neither engines nor accessories can be modified. By this we mean any shape, content or function changes which may differ from what originally produced (manufactured and assembled). Furthermore this includes any addition and /or removal of material.

All dimensions in the technical drawings are in mm.

TOUTES LES PARTIES DU MOTEUR DOIVENT ÊTRE ORIGINALES VORTEX ROK.

Ni le moteur ni les accessoires peuvent être modifiés, qu'il s'agisse d'un changement de forme, de contenu ou de fonctionnement, représentant une condition de différence par rapport à sa construction d'origine (produit et assemblé), ci-inclus aussi l'addition et/ou l'enlèvement de matériaux. Toutes les cotes dans les dessins techniques sont en mm.

ATTENTION

MINI ROK 2025

CAMPANA E ROTORE HOUSING AND ROTOR ROTOR ET BELL

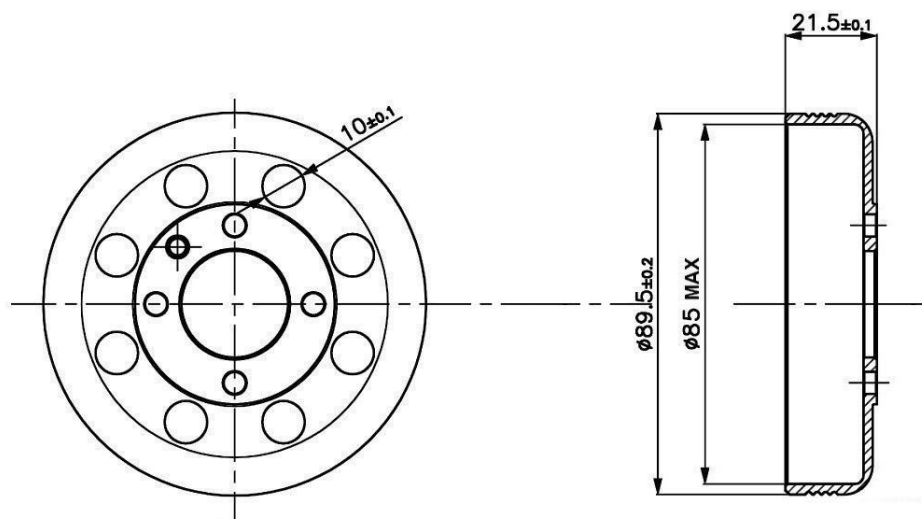

**PESO DELLA CAMPANA
WEIGHT OF CLUTCH HOUSING
POIDS DU BELL**

177gr +/- 5gr 177gr +/- 15gr

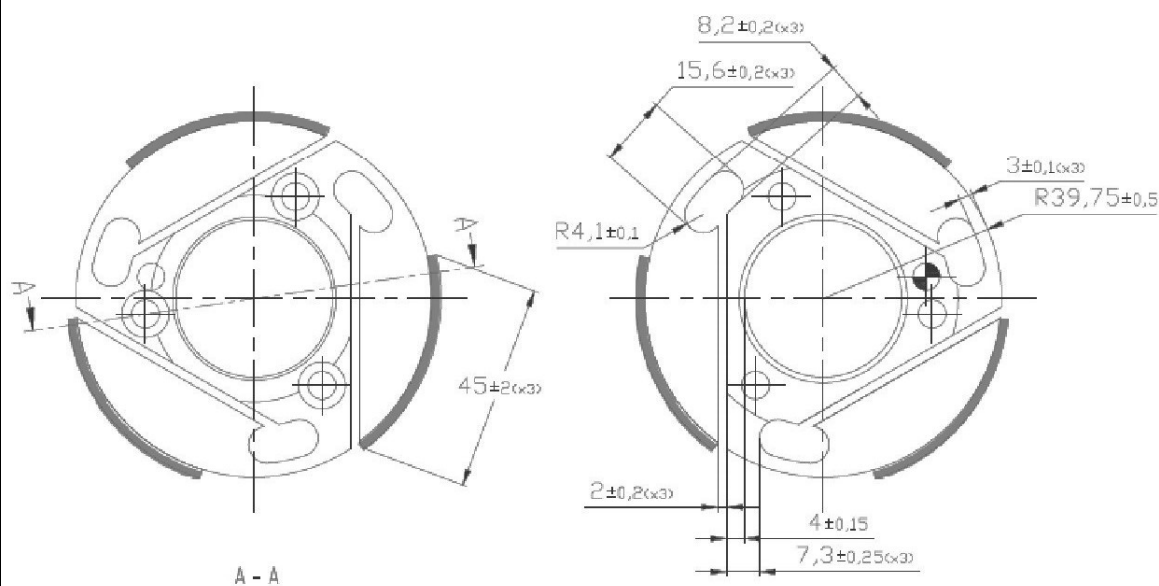

**PESO DEL ROTORE FRIZIONE
WEIGHT OF CLUTCH ROTOR
POIDS DU ROTOR EMBRAYAGE**

356 gr +/- 10g 356 gr +/- 20g

ATTENTION

TUTTI LE PARTI DEL MOTORE DEVONO ESSERE ORIGINALI VORTEX ROK.

Né il motore né gli accessori possono essere in alcun modo modificati, per modifica si intende qualsiasi cambiamento di forma, contenuto o funzione, che rappresenti una condizione di differenza da quanto originariamente costruito (prodotto ed assemblato), inclusa l'aggiunta e/o l'asportazione di materiale. Tutte le misure dimensionali nei disegni tecnici si intendono in mm.

ALL THE ENGINE PARTS MUST BE ORIGINAL BY VORTEX ROK.

Neither engines nor accessories can be modified. By this we mean any shape, content or function changes which may differ from what originally produced (manufactured and assembled). Furthermore this includes any addition and /or removal of material.

All dimensions in the technical drawings are in mm.

TOUTES LES PARTIES DU MOTEUR DOIVENT ETRE ORIGINALES VORTEX ROK.

Ni le moteur ni les accessoires peuvent être modifiés, qu'il s'agisse d'un changement de forme, de contenu ou de fonctionnement, représentant une condition de différence par rapport à sa construction d'origine (produit et assemblé), ci-inclus aussi l'addition et/ou l'enlèvement de matériaux. Toutes les cotes dans les dessins techniques sont en mm.

MINI ROK 2025

MARMITTA EXHAUST MUFFLER ECHAPEMENT

MISURA COLLETTORE COMPRESA SALDATURA.
DIMENSION OF COLLECTOR INCLUDING WELDING.
DIMENSION COLLECTEUR COMPRIS SOUDAGE.

PESO MARMITTA
EXHAUST WEIGHT
POIDS D'ECHAPEMENT

1,372gr +/- 5%

A=190±3
B=240±3
C= DIAMETRO EST. 31±1.5

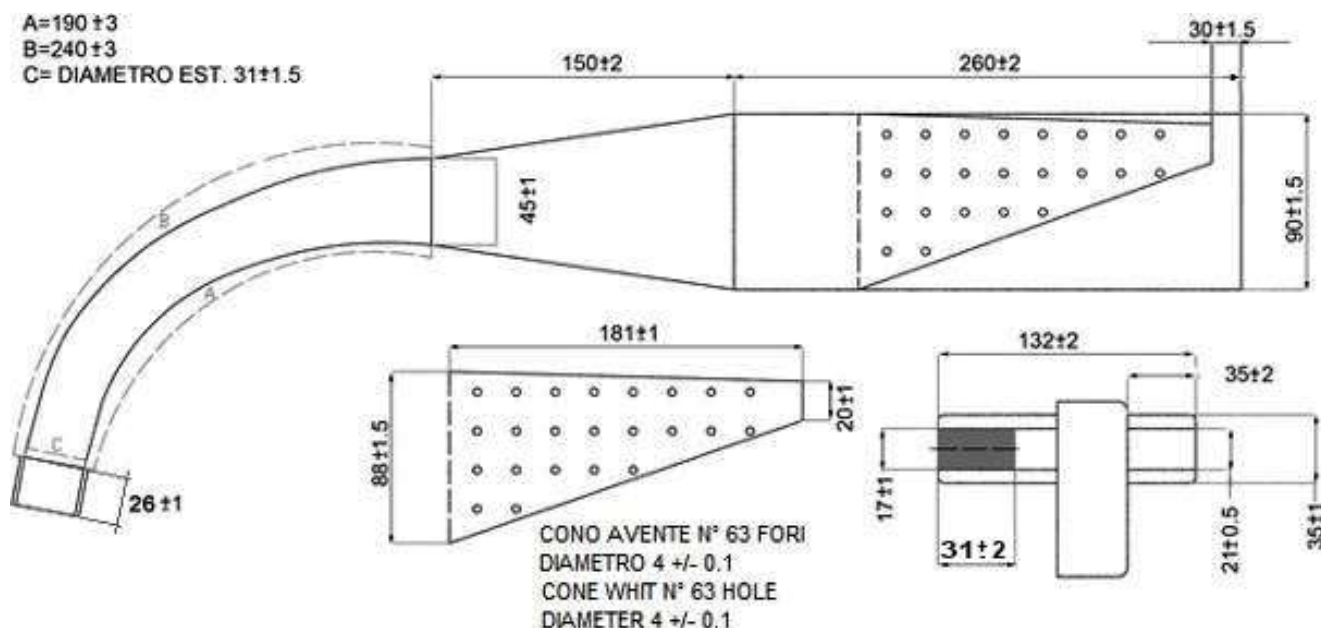

ATTENTION

TUTTI LE PARTI DEL MOTORE DEVONO ESSERE ORIGINALI VORTEX ROK.

Né il motore né gli accessori possono essere in alcun modo modificati, per modifica si intende qualsiasi cambiamento di forma, contenuto o funzione, che rappresenti una condizione di differenza da quanto originariamente costruito (prodotto ed assemblato), inclusa l'aggiunta e/o l'asportazione di materiale. Tutte le misure dimensionali nei disegni tecnici si intendono in mm.

ALL THE ENGINE PARTS MUST BE ORIGINAL BY VORTEX ROK.

Neither engines nor accessories can be modified. By this we mean any shape, content or function changes which may differ from what originally produced (manufactured and assembled). Furthermore this includes any addition and /or removal of material.

All dimensions in the technical drawings are in mm.

TOUTES LES PARTIES DU MOTEUR DOIVENT ETRE ORIGINALES VORTEX ROK.

Ni le moteur ni les accessoires peuvent être modifiés, qu'il s'agisse d'un changement de forme, de contenu ou de fonctionnement, représentant une condition de différence par rapport à sa construction d'origine (produit et assemblé), ci-inclus aussi l'addition et/ou l'enlèvement de matériaux. Toutes les cotes dans les dessins techniques sont en mm.

MINI ROK 2025

FOTO E MARCHIATURA DELLA MARMITTA
 PHOTO AND MARKING OF THE EXHAUST
 PHOTO ET MARQUAGE DE L'ÉCHAPPEMENT



SULLA MARMITTA DEVE ESSERE PRESENTE IN SEDE DI VERIFICA IL LOGO DI RICONOSCIMENTO ROK MINI.

DURING EXAMINATION, ON THE EXHAUST IT MUST BE INDICATED THE IDENTIFICATION LOGO ROK MINI.

PENDANT LA VERIFICATION, SUR LE POT D'ÉCHAPPEMENT, IL DOIT ÊTRE PRÉSENT LE LOGO DE RECONNAISSANCE ROK MINI.

ATTENTION

TUTTI LE PARTI DEL MOTORE DEVONO ESSERE ORIGINALI VORTEX ROK.

Né il motore né gli accessori possono essere in alcun modo modificati, per modifica si intende qualsiasi cambiamento di forma, contenuto o funzione, che rappresenti una condizione di differenza da quanto originariamente costruito (prodotto ed assemblato), inclusa l'aggiunta e/o l'asportazione di materiale. Tutte le misure dimensionali nei disegni tecnici si intendono in mm.

ALL THE ENGINE PARTS MUST BE ORIGINAL BY VORTEX ROK.

Neither engines nor accessories can be modified. By this we mean any shape, content or function changes which may differ from what originally produced (manufactured and assembled). Furthermore this includes any addition and /or removal of material.

All dimensions in the technical drawings are in mm.

TOUTES LES PARTIES DU MOTEUR DOIVENT ÊTRE ORIGINALES VORTEX ROK.

Ni le moteur ni les accessoires peuvent être modifiés, qu'il s'agisse d'un changement de forme, de contenu ou de fonctionnement, représentant une condition de différence par rapport à sa construction d'origine (produit et assemblé), ci-inclus aussi l'addition et/ou l'enlèvement de matériaux. Toutes les cotes dans les dessins techniques sont en mm.

MINI ROK 2025

**COLLETTORE DI SCARICO
EXHAUST MANIFOLD
COLLECTEUR ECHAPPEMENT**

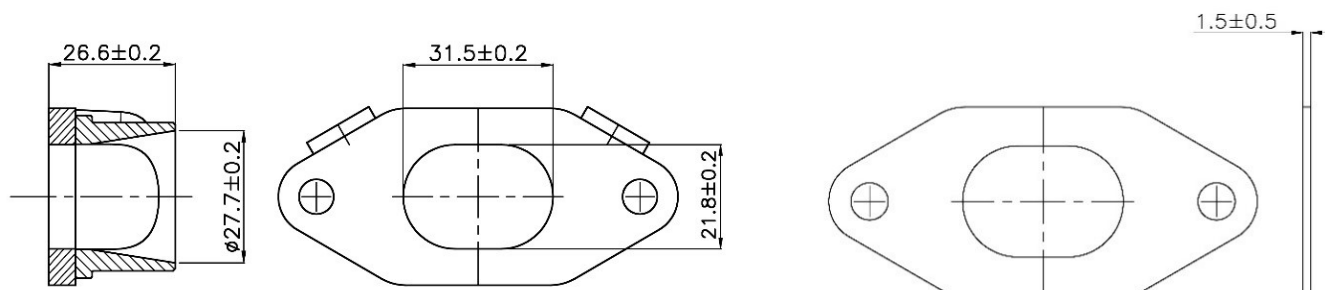

ATTENTION

TUTTI LE PARTI DEL MOTORE DEVONO ESSERE ORIGINALI VORTEX ROK.

Né il motore né gli accessori possono essere in alcun modo modificati, per modifica si intende qualsiasi cambiamento di forma, contenuto o funzione, che rappresenti una condizione di differenza da quanto originariamente costruito (prodotto ed assemblato), inclusa l'aggiunta e/o l'asportazione di materiale. Tutte le misure dimensionali nei disegni tecnici si intendono in mm.

ALL THE ENGINE PARTS MUST BE ORIGINAL BY VORTEX ROK.

Neither engines nor accessories can be modified. By this we mean any shape, content or function changes which may differ from what originally produced (manufactured and assembled). Furthermore this includes any addition and /or removal of material.

All dimensions in the technical drawings are in mm.

TOUTES LES PARTIES DU MOTEUR DOIVENT ETRE ORIGINALES VORTEX ROK.

Ni le moteur ni les accessoires peuvent être modifiés, qu'il s'agisse d'un changement de forme, de contenu ou de fonctionnement, représentant une condition de différence par rapport à sa construction d'origine (produit et assemblé), ci-inclus aussi l'addition et/ou l'enlèvement de matériaux. Toutes les cotes dans les dessins techniques sont en mm.

MINI ROK 2025

FILTRO D'ASPIRAZIONE INLET SILENCER SILENCIEUX D'ASPIRATION	
MODELLO, TIPO MODEL, TYPE MODELE, TYPE	MINI
<p> MARCHIATO VORTEX MARKED VORTEX MARQUE VORTEX </p> <p> RETINA OPZIONALE AIR FILTER MESH AS OPTIONAL. FILTRE FILET EN OPTION </p>	
OPTION 1	OPTION 2

ATTENTION	<p> <u>TUTTI LE PARTI DEL MOTORE DEVONO ESSERE ORIGINALI VORTEX ROK.</u> Né il motore né gli accessori possono essere in alcun modo modificati, per modifica si intende qualsiasi cambiamento di forma, contenuto o funzione, che rappresenti una condizione di differenza da quanto originariamente costruito (prodotto ed assemblato), inclusa l'aggiunta e/o l'asportazione di materiale. Tutte le misure dimensionali nei disegni tecnici si intendono in mm. </p> <p> <u>ALL THE ENGINE PARTS MUST BE ORIGINAL BY VORTEX ROK.</u> Neither engines nor accessories can be modified. By this we mean any shape, content or function changes which may differ from what originally produced (manufactured and assembled). Furthermore this includes any addition and /or removal of material. All dimensions in the technical drawings are in mm. </p> <p> <u>TOUTES LES PARTIES DU MOTEUR DOIVENT ETRE ORIGINALES VORTEX ROK.</u> Ni le moteur ni les accessoires peuvent être modifiés, qu'il s'agisse d'un changement de forme, de contenu ou de fonctionnement, représentant une condition de différence par rapport à sa construction d'origine (produit et assemblé), ci-inclus aussi l'addition et/ou l'enlèvement de matériaux. Toutes les cotes dans les dessins techniques sont en mm. </p>
-----------	---

MINI ROK 2025

**DISEGNO TECNICO GUARNIZIONE TRA CRBURATORE E MOTORE
TECHNICAL DRAWING GASKET BETWEEN CARBURETTOR AND ENGINE
DESSIN TECHNIQUE JOINT ENTRE CARBURATEUR ET MOTEUR**

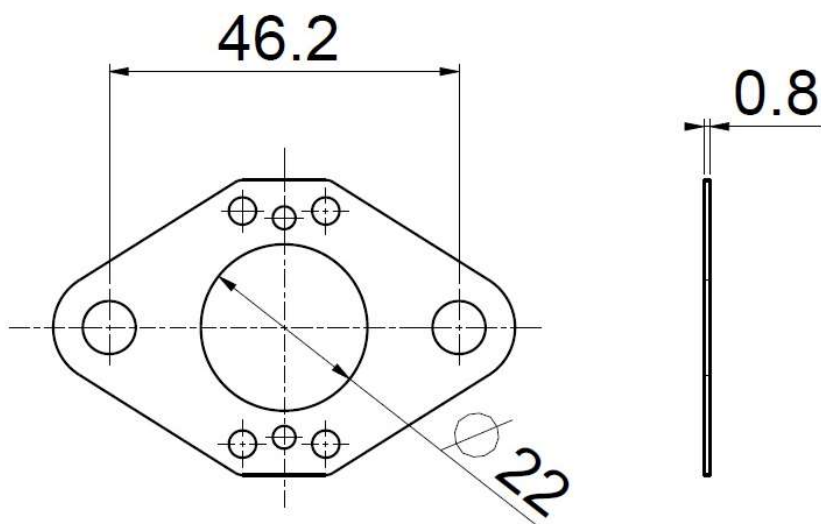

ATTENTION

TUTTI LE PARTI DEL MOTORE DEVONO ESSERE ORIGINALI VORTEX ROK.

Né il motore né gli accessori possono essere in alcun modo modificati, per modifica si intende qualsiasi cambiamento di forma, contenuto o funzione, che rappresenti una condizione di differenza da quanto originariamente costruito (prodotto ed assemblato), inclusa l'aggiunta e/o l'asportazione di materiale. Tutte le misure dimensionali nei disegni tecnici si intendono in mm.

ALL THE ENGINE PARTS MUST BE ORIGINAL BY VORTEX ROK.

Neither engines nor accessories can be modified. By this we mean any shape, content or function changes which may differ from what originally produced (manufactured and assembled). Furthermore this includes any addition and /or removal of material.

All dimensions in the technical drawings are in mm.

TOUTES LES PARTIES DU MOTEUR DOIVENT ETRE ORIGINALES VORTEX ROK.

Ni le moteur ni les accessoires peuvent être modifiés, qu'il s'agisse d'un changement de forme, de contenu ou de fonctionnement, représentant une condition de différence par rapport à sa construction d'origine (produit et assemblé), ci-inclus aussi l'addition et/ou l'enlèvement de matériaux. Toutes les cotes dans les dessins techniques sont en mm.

MINI ROK 2025

FOTO ACCENSIONE SELETTRA
PICTURES OF SELETTRA IGNITION
PHOTO ALLUMAGE



WIRING CABLE FREE

ATTENTION

TUTTI LE PARTI DEL MOTORE DEVONO ESSERE ORIGINALI VORTEX ROK.

Né il motore né gli accessori possono essere in alcun modo modificati, per modifica si intende qualsiasi cambiamento di forma, contenuto o funzione, che rappresenti una condizione di differenza da quanto originariamente costruito (prodotto ed assemblato), inclusa l'aggiunta e/o l'asportazione di materiale. Tutte le misure dimensionali nei disegni tecnici si intendono in mm.

ALL THE ENGINE PARTS MUST BE ORIGINAL BY VORTEX ROK.

Neither engines nor accessories can be modified. By this we mean any shape, content or function changes which may differ from what originally produced (manufactured and assembled). Furthermore this includes any addition and /or removal of material.

All dimensions in the technical drawings are in mm.

TOUTES LES PARTIES DU MOTEUR DOIVENT ETRE ORIGINALES VORTEX ROK.

Ni le moteur ni les accessoires peuvent être modifiés, qu'il s'agisse d'un changement de forme, de contenu ou de fonctionnement, représentant une condition de différence par rapport à sa construction d'origine (produit et assemblé), ci-inclus aussi l'addition et/ou l'enlèvement de matériaux. Toutes les cotes dans les dessins techniques sont en mm.

MINI ROK 2025

**E' obbligatorio che il motore si accenda e si spenga con il sistema di avviamento on board.
I commissari tecnici potranno verificare il sistema di accensione e spegnimento in qualsiasi momento.**

**Engines shall be mandatory switched on and off by means of onboard starting system.
Technical stewart members shall check the on-off onboard system anytime.**

**Il est obligatoire que le moteur soit allumé et éteint au moyen du système de démarrage sur le chassis.
Les commissaires pourront effectuer des controles au système de démarrage et d'arrêt à tout moment.**

DISEGNO TECNICO DEL COLLETTORE DI ASPIRAZIONE INTAKE MANIFOLD TECHNICAL DRAWING DESSIN TECHNIQUE DU COLLECTEUR D'ADMISSION



FOTO DEL COLLETTORE DI ASPIRAZIONE INTAKE MANIFOLD PHOTO PHOTO DU COLLECTEUR D'ADMISSION

ATTENTION

TUTTI LE PARTI DEL MOTORE DEVONO ESSERE ORIGINALI VORTEX ROK.

Né il motore né gli accessori possono essere in alcun modo modificati, per modifica si intende qualsiasi cambiamento di forma, contenuto o funzione, che rappresenti una condizione di differenza da quanto originariamente costruito (prodotto ed assemblato), inclusa l'aggiunta e/o l'asportazione di materiale. Tutte le misure dimensionali nei disegni tecnici si intendono in mm.

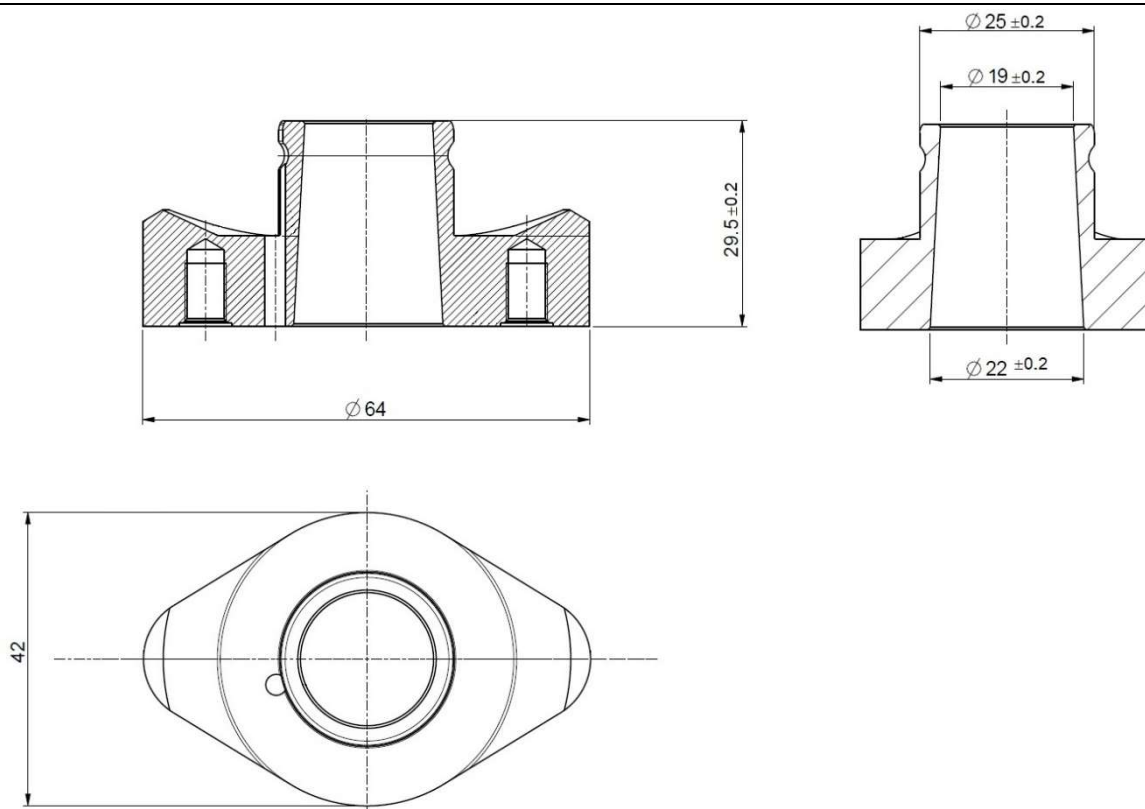
ALL THE ENGINE PARTS MUST BE ORIGINAL BY VORTEX ROK.

Neither engines nor accessories can be modified. By this we mean any shape, content or function changes which may differ from what originally produced (manufactured and assembled). Furthermore this includes any addition and /or removal of material.

All dimensions in the technical drawings are in mm.

TOUTES LES PARTIES DU MOTEUR DOIVENT ETRE ORIGINALES VORTEX ROK.

Ni le moteur ni les accessoires peuvent être modifiés, qu'il s'agisse d'un changement de forme, de contenu ou de fonctionnement, représentant une condition de différence par rapport à sa construction d'origine (produit et assemblé), ci-inclus aussi l'addition et/ou l'enlèvement de matériaux. Toutes les cotes dans les dessins techniques sont en mm.

MINI ROK 2025



FOTO DEL SUPPORTO IN GOMMA DEL COLLETTORE DI ASPIRAZIONE
 PHOTO OF INTAKE MANIFOLD RUBBER MOUNT
 PHOTO DU SUPPORT EN CAOUTCHOUC DU COLLECTEUR D'ADMISSION



FOTO DEL MONTAGGIO DEL GRUPPO DI ASPIRAZIONE
 PHOTO OF THE ASSEMBLY OF THE INTAKE GROUP
 PHOTO DU MONTAGE DU GROUPE D'ADMISSION

ATTENTION	<p><u>TUTTI LE PARTI DEL MOTORE DEVONO ESSERE ORIGINALI VORTEX ROK.</u> Né il motore né gli accessori possono essere in alcun modo modificati, per modifica si intende qualsiasi cambiamento di forma, contenuto o funzione, che rappresenti una condizione di differenza da quanto originariamente costruito (prodotto ed assemblato), inclusa l'aggiunta e/o l'asportazione di materiale. Tutte le misure dimensionali nei disegni tecnici si intendono in mm.</p> <p><u>ALL THE ENGINE PARTS MUST BE ORIGINAL BY VORTEX ROK.</u> Neither engines nor accessories can be modified. By this we mean any shape, content or function changes which may differ from what originally produced (manufactured and assembled). Furthermore this includes any addition and /or removal of material. All dimensions in the technical drawings are in mm.</p> <p><u>TOUTES LES PARTIES DU MOTEUR DOIVENT ETRE ORIGINALES VORTEX ROK.</u> Ni le moteur ni les accessoires peuvent être modifiés, qu'il s'agisse d'un changement de forme, de contenu ou de fonctionnement, représentant une condition de différence par rapport à sa construction d'origine (produit et assemblé), ci-inclus aussi l'addition et/ou l'enlèvement de matériaux. Toutes les cotes dans les dessins techniques sont en mm.</p>
------------------	--

MINI ROK 2025

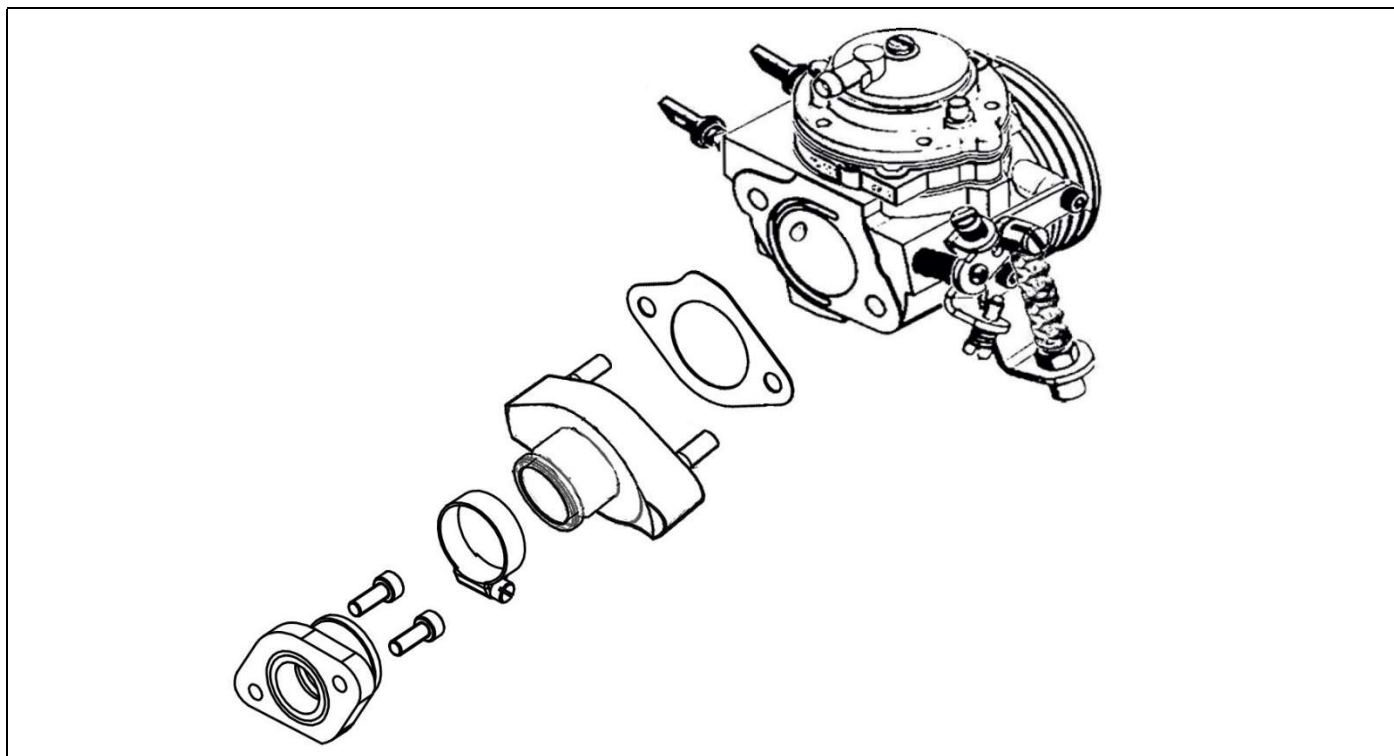

ATTENTION

TUTTI LE PARTI DEL MOTORE DEVONO ESSERE ORIGINALI VORTEX ROK.

Né il motore né gli accessori possono essere in alcun modo modificati, per modifica si intende qualsiasi cambiamento di forma, contenuto o funzione, che rappresenti una condizione di differenza da quanto originariamente costruito (prodotto ed assemblato), inclusa l'aggiunta e/o l'asportazione di materiale. Tutte le misure dimensionali nei disegni tecnici si intendono in mm.

ALL THE ENGINE PARTS MUST BE ORIGINAL BY VORTEX ROK.

Neither engines nor accessories can be modified. By this we mean any shape, content or function changes which may differ from what originally produced (manufactured and assembled). Furthermore this includes any addition and /or removal of material.

All dimensions in the technical drawings are in mm.

TOUTES LES PARTIES DU MOTEUR DOIVENT ETRE ORIGINALES VORTEX ROK.

Ni le moteur ni les accessoires peuvent être modifiés, qu'il s'agisse d'un changement de forme, de contenu ou de fonctionnement, représentant une condition de différence par rapport à sa construction d'origine (produit et assemblé), ci-inclus aussi l'addition et/ou l'enlèvement de matériaux. Toutes les cotes dans les dessins techniques sont en mm.

MINI ROK ENGINE INTAKE GAP CONTROL

<p>1</p>	<p>2</p>
<p>TURN CLOCKWISE AND LIFT THE PISTON TO ALLOW THE INSERTION OF THE FEELER GAUGE AGAINST THE LOWER EXHAUST EDGE.</p>	<p>TURN COUNTERCLOCKWISE AND LOWER THE PISTON UNTIL IT MEETS THE GAUGE RESTING AT THE EXHAUST EDGE, AT THIS STAGE SET THE SCALE ON THE POSITION OF 0 DEGREES.</p>
<p>3</p>	<p>4</p>
<p>RELEASE THE FEELER GAUGE AND TURNING COUNTERCLOCKWISE LOWER THE PISTON TO ALLOW THE INSERTION OF THE FEELER UNDER THE UPPER EDGE OF THE EXHAUST.</p>	<p>TURN COUNTERCLOCKWISE TO LIFT THE PISTON UNTIL IT MEETS THE FEELER GAUGE RESTING AT THE EXHAUST EDGE. AT THIS STAGE CHECK THAT THE EDGE OF DISPLACEMENTS OF THE VERNIER MATCH NOT LESS THAN 31 DEGREES.</p>

MINI ROK 2025



2025 TECHNICAL APENDIX MINI ROK

- 1. Fuel System:**
 - a. All fuel system components must be utilized as supplied.**
 - b. No additional components are permitted.**
 - c. Any fuel filter must be fixed between the carburetor and the fuel tank, and no additional component**

- 2. Carburetor:**
 - a. The only allowed carburetor is the Tillotson HW-38A.**
 - b. Replacement parts must be of the same type and size as originally supplied.**

- 3. Air box**
 - a. ROK foam air filter insert is optional.**
 - b. Air box must not contain any additional holes**
 - c. No external form of air ducts forcing air inside of air box is permitted.**
 - d. Air box must be secured completely after each track event otherwise last place position is given.**
 - e. Plastic protection under rain conditions is allowed.**
 - f. Trimming of excess rubber of airbox boot is permitted.**

- 4. Cylinder Head CC. Volume / Squish:**
 - a. Minimum squish is .75mm. Measured with 2mm Rotax #9735 Solder. Tech will measure across the pin and take an average from side to side if required.**

- 5. Coil**
 - a. Must be mounted as supplied**
 - b. Must be mounted to the engine**
 - c. Must use coil as supplied**

MINI ROK 2025



6. Wiring Harness:

- a. Wire Harness is open and optional.

7. Battery:

- a. Battery may be as supplied or any lightweight battery as long as it is securely mounted to the original battery box. No battery or battery box is also allowed.
- b. Battery must fit inside supplied battery box.
- c. A secondary battery is allowed to power data systems only. Mychron, Unipro, Alfano, etc

8. Spark plug:

- a. Only the following plugs allowed:
 - i. NGK B/BR 9EG, 10EG
 - ii. Must be original and no modification is allowed.
- b. Spark plug washer or head temperature gauge sender must be in place.
- c. Spark Plug Cap must be as supplied.

9. Exhaust Pipe:

- a. No treatment of any kind.
- b. No sand blasting is allowed.
- c. No form of thermo wrapping is allowed.
- d. Internal dimensions may not be altered because of rust.
- e. No modifications to silencer end cap.
- f. Exhaust temperature sensor:
 - i. One exhaust temperature sensor is allowed.
 - ii. One hole only can be drilled on the exhaust pipe for sensor.
 - iii. No specific location is required for the exhaust temperature sensor.
 - iv. Any hole not being used must be completely plugged if exhaust sensor is not being used.

10. Exhaust header:

- a. Restrictor as per Homologation File.
 - i. MINI-ROK
- b. Restrictor headers cannot be cracked or leaking.
- c. A go-no go gauge will be used to control restrictor headers.

11. Clutch:

- a. Any form of Lubricant must not be added to the clutch components.
- b. Oil/dust shield is recommended but not mandatory.

12. Ignition Timing:

- a. Standard (3mm.) +/- 1 mm.

13. Treatment:

- a. No treatments or paint may be done to any parts including engine and exhaust components.

MINI ROK 2025



- b. Inspectors are allowed to paint any engine component for technical purpose.

14. External Modifications:

- a. Any modification not clearly described inside this document is not to be taken as legally acceptable.

15. Chassis

- a. Wheelbase 900mm. or 950mm. **ONLY**.

16. Fuel and Oil

- a. Spec racing fuel for all Rok Categories is Sunoco STANDARD 110.
- b. Spec racing oil is Motul 2T.
- c. No other oil or additives are allowed.

17. Engine Eligibility

- a. Canadian license holders must use Engines with a Canadian serial numbers.
- b. International drivers may use non-Canadian engines provided they comply with the Vortex Canada technical regulations.
- c. Engine eligibility list will be available on-line <https://goodwoodkartways.com/vortexcanada/> and from tech director. If engine is not on the list you will need submit proof of Canadian purchase to tech director.