

SCHEDA D'IDENTIFICAZIONE
IDENTIFICATION SHEET
FICHE D'IDENTIFICATION

La presente scheda di identificazione riproduce descrizioni, illustrazioni e dimensioni del motore **VLR ROK**.
 This Identification Sheet reproduces descriptions, illustrations and dimensions of the **VLR ROK**.
 La présente Fiche d'Identification reproduit descriptions, illustrations et dimensions du moteur **VLR ROK**.

ATTENTION
TUTTI LE PARTI DEL MOTORE DEVONO ESSERE ORIGINALI VORTEX ROK.

Né il motore né gli accessori possono essere in alcun modo modificati, per modifica si intende qualsiasi cambiamento di forma, contenuto o funzione, che rappresenti una condizione di differenza da quanto originariamente costruito (prodotto ed assemblato), inclusa l'aggiunta e/o l'asportazione di materiale. Tutte le misure dimensionali nei disegni tecnici si intendono in mm.

ALL THE ENGINE PARTS MUST BE ORIGINAL BY VORTEX ROK.

Neither engines nor accessories can be modified. By this we mean any shape, content or function changes which may differ from what originally produced (manufactured and assembled). Furthermore this includes any addition and /or removal of material.

All dimensions in the technical drawings are in mm.

TOUTES LES PARTS DU MOTEUR DOIVENT ETRE ORIGINALES VORTEX ROK.

Ni le moteur ni les accessoires peuvent être modifiés. Modification signifie tout changement de forme, de contenu ou de fonction, ce qui représente une condition de différence avec ce qui a été construit à l'origine (produit et assemblé). Ci-inclus aussi l'addition et/ou l'enlèvement de matériaux. Toutes les mesures dimensionnelles dans les dessins techniques sont en mm.



VLR / VLR-JUNIOR ROK 2025

INFORMAZIONI DI BASE E CARATTERISTICHE TECNICHE TECHNICAL INFORMATION AND CHARACTERISTICS INFORMATION DE BASE ET CARACTÉRISTIQUES TECHNIQUES			
ALESAGGIO ORIGINALE	ORIGINAL BORE	ALESAGE D'ORIGINE	42,20 mm +/-0,2mm
ALESAGGIO MASSIMO	MAX ALLOWED BORE	ALESAGE MAXIMUM	48.53 mm
CORSA	STROKE	COURSE	54mm +/- 0,2 mm
CILINDRATA ORIGINALE	ORIGINAL DISPLACEMENT	CAPACITE' D'ORIGINE	100 cc
INTERASSE BIELLA	CONROD C-TO-C DISTANCE	ENTRAXE DE LE BIELLE	102mm +/- 0,2 mm
PESO DELLA BIELLA	WEIGHT OF CONROD	POID DE LA BIELLE	127g +/- 2g
PIGNONE	SPROCKET	PIGNON	Z10-Z11-Z12

SVILUPPO DEL CILINDRO E DISTRIBUZIONE CYLINDER DEVELOPEMENT AND DISTRIBUTION DEVELOPPEMENT DU CYLINDRE ET DISTRIBUTION			
SCARICO	EXHAUST PORT	ECHAPPEMENT	169° MAX
BOOSTER	BOOSTER	BOOSTER	167° MAX
TRAVASI PRINCIPALI	MAIN TRANSFER	TRANSFERES PRINCIPAL	123,5° ± 2°
TRAVASI SECONDARI	SECONDARY TRANSFER	ADMISSION SECONDAIRES	132° MAX

Controllo della distribuzione come descritto nel **Regolamento Tecnico del Trofeo di Marca ROK CUP USA 2024.**
Check of the distribution as described in the **ROK CUP USA 2024 Technical Regulation.**
Contrôle de la distribution tel que décrit dans le **Règlement technique du trophée de la marque ROK CUP USA 2024.**

Il controllo deve essere effettuato a testa montata (coppia di serraggio prigionieri: 1.8 kgm).
Measurement must be done with engine head mantled (studs tightening torque: 1.8 kgm).
Le contrôle doit être effectué avec la tête montée (couple de serrage des goujons: 1.8 kgm).

ATTENTION	<u>TUTTI LE PARTI DEL MOTORE DEVONO ESSERE ORIGINALI VORTEX ROK.</u>
	Né il motore né gli accessori possono essere in alcun modo modificati, per modifica si intende qualsiasi cambiamento di forma, contenuto o funzione, che rappresenti una condizione di differenza da quanto originariamente costruito (prodotto ed assemblato), inclusa l'aggiunta e/o l'asportazione di materiale. Tutte le misure dimensionali nei disegni tecnici si intendono in mm.
	<u>ALL THE ENGINE PARTS MUST BE ORIGINAL BY VORTEX ROK.</u>
	Neither engines nor accessories can be modified. By this we mean any shape, content or function changes which may differ from what originally produced (manufactured and assembled). Furthermore this includes any addition and /or removal of material. All dimensions in the technical drawings are in mm.
	<u>TOUTES LES PARTS DU MOTEUR DOIVENT ETRE ORIGINALES VORTEX ROK.</u>
	Ni le moteur ni les accessoires peuvent être modifiés. Modification signifie tout changement de forme, de contenu ou de fonction, ce qui représente une condition de différence avec ce qui a été construit à l'origine (produit et assemblé). Ci-inclus aussi l'addition et/ou l'enlèvement de matériaux. Toutes les mesures dimensionnelles dans les dessins techniques sont en mm.

VLR / VLR-JUNIOR ROK 2025

SEZIONE DEL CILINDRO
CYLINDER SECTION
COUPE PAR SECTION DU CYLINDRE

DISTANZA MINIMA DEL PIANO APPOGGIO COLLETTORE SCARICO DALL' ASSE DEL CILINDRO
MINIMUM DISTANCE OF THE EXHAUST MANIFOLD PLAN FROM THE CYLINDER AXLE
DISTANCE MINIMAL DU SOL DU COLLECTEUR ECHAPPEMENT OU CYLINDRE

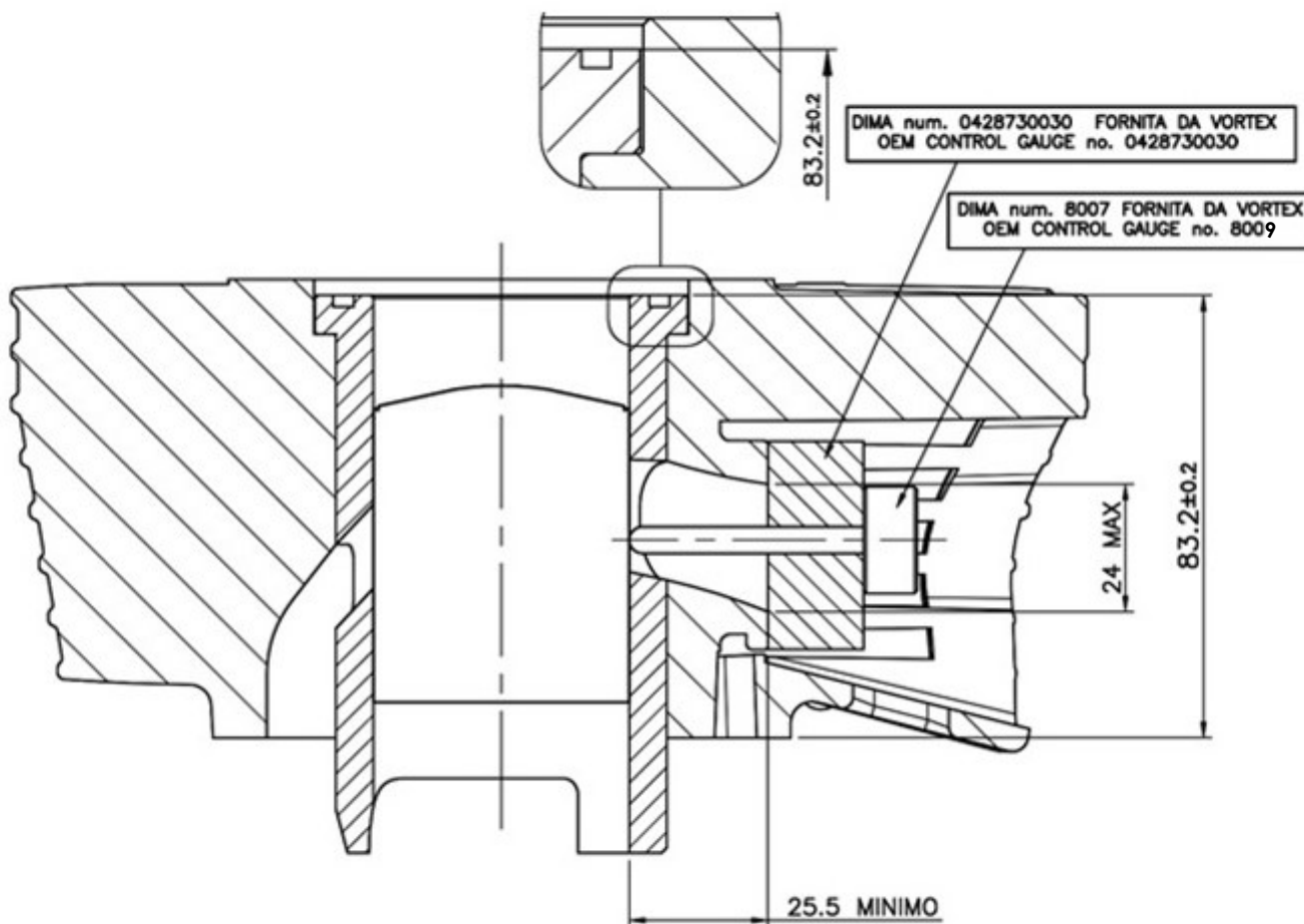

ATTENTION

TUTTI LE PARTI DEL MOTORE DEVONO ESSERE ORIGINALI VORTEX ROK.

Né il motore né gli accessori possono essere in alcun modo modificati, per modifica si intende qualsiasi cambiamento di forma, contenuto o funzione, che rappresenti una condizione di differenza da quanto originariamente costruito (prodotto ed assemblato), inclusa l'aggiunta e/o l'asportazione di materiale. Tutte le misure dimensionali nei disegni tecnici si intendono in mm.

ALL THE ENGINE PARTS MUST BE ORIGINAL BY VORTEX ROK.

Neither engines nor accessories can be modified. By this we mean any shape, content or function changes which may differ from what originally produced (manufactured and assembled). Furthermore this includes any addition and /or removal of material.

All dimensions in the technical drawings are in mm.

TOUTES LES PARTS DU MOTEUR DOIVENT ETRE ORIGINALES VORTEX ROK.

Ni le moteur ni les accessoires peuvent être modifiés. Modification signifie tout changement de forme, de contenu ou de fonction, ce qui représente une condition de différence avec ce qui a été construit à l'origine (produit et assemblé). Ci-inclus aussi l'addition et/ou l'enlèvement de matériaux. Toutes les mesures dimensionnelles dans les dessins techniques sont en mm.

VLR / VLR-JUNIOR ROK 2025

**DISEGNO DELLA TESTA E CAMERA DI COMBUSTIONE
DRAWING OF CYLINDERHEAD AND COMBUSTION CHAMBER
DISSIN DU CULASSE ET CHAMBRE DE COMBUSTION**

VOLUME DELLA CAMERA DI COMBUSTIONE	VOLUME OF COMBUSTION CHAMBER	VOLUME DE LA CHAMBRE DE COMBUSTION	8,60 cc MIN. With FIA Insert
------------------------------------	------------------------------	------------------------------------	------------------------------

Average taken from both sides of the piston, using Rotax 2.0mm solder 100g #9735

SQUISH THICKNESS – SQUISH - EPESSEUR DE SQUISH : 1mm MIN

**DIMA CONTROLLO PROFILO CAMERA DI COMBUSTIONE
TEMPLATE FOR CHECKING THE COMBUSTION
CHAMBER PROFILE
GABARIT POUR LA VERIFICATION DU PROFIL DE LA
CHAMBRE DE COMBUSTION**

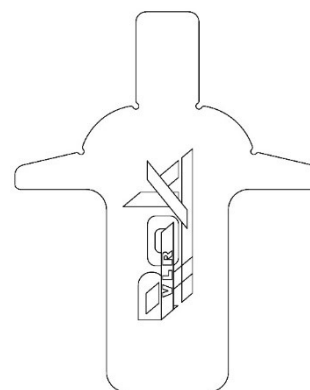
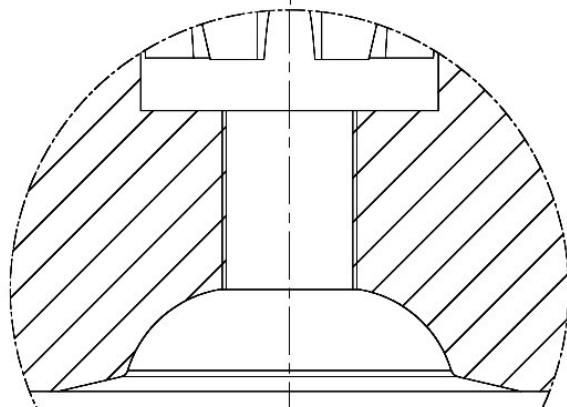
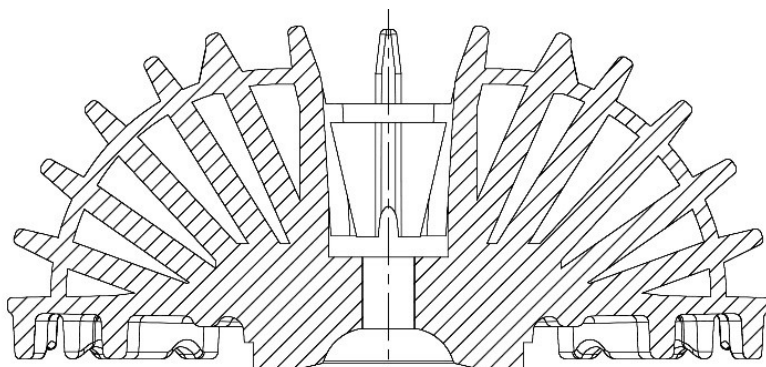

ATTENTION

TUTTI LE PARTI DEL MOTORE DEVONO ESSERE ORIGINALI VORTEX ROK.

Né il motore né gli accessori possono essere in alcun modo modificati, per modifica si intende qualsiasi cambiamento di forma, contenuto o funzione, che rappresenti una condizione di differenza da quanto originariamente costruito (prodotto ed assemblato), inclusa l'aggiunta e/o l'asportazione di materiale. Tutte le misure dimensionali nei disegni tecnici si intendono in mm.

ALL THE ENGINE PARTS MUST BE ORIGINAL BY VORTEX ROK.

Neither engines nor accessories can be modified. By this we mean any shape, content or function changes which may differ from what originally produced (manufactured and assembled). Furthermore this includes any addition and /or removal of material.

All dimensions in the technical drawings are in mm.

TOUTES LES PARTS DU MOTEUR DOIVENT ETRE ORIGINALES VORTEX ROK.

Ni le moteur ni les accessoires peuvent être modifiés. Modification signifie tout changement de forme, de contenu ou de fonction, ce qui représente une condition de différence avec ce qui a été construit à l'origine (produit et assemblé). Ci-inclus aussi l'addition et/ou l'enlèvement de matériaux. Toutes les mesures dimensionnelles dans les dessins techniques sont en mm.

VLR / VLR-JUNIOR ROK 2025

ALBERO MOTORE E ASSE D'ACCOPIAMENTO CRANKSHAFT AND CRANKPIN VILEBREQUIN ET AXE DE VILLEBREQUIN

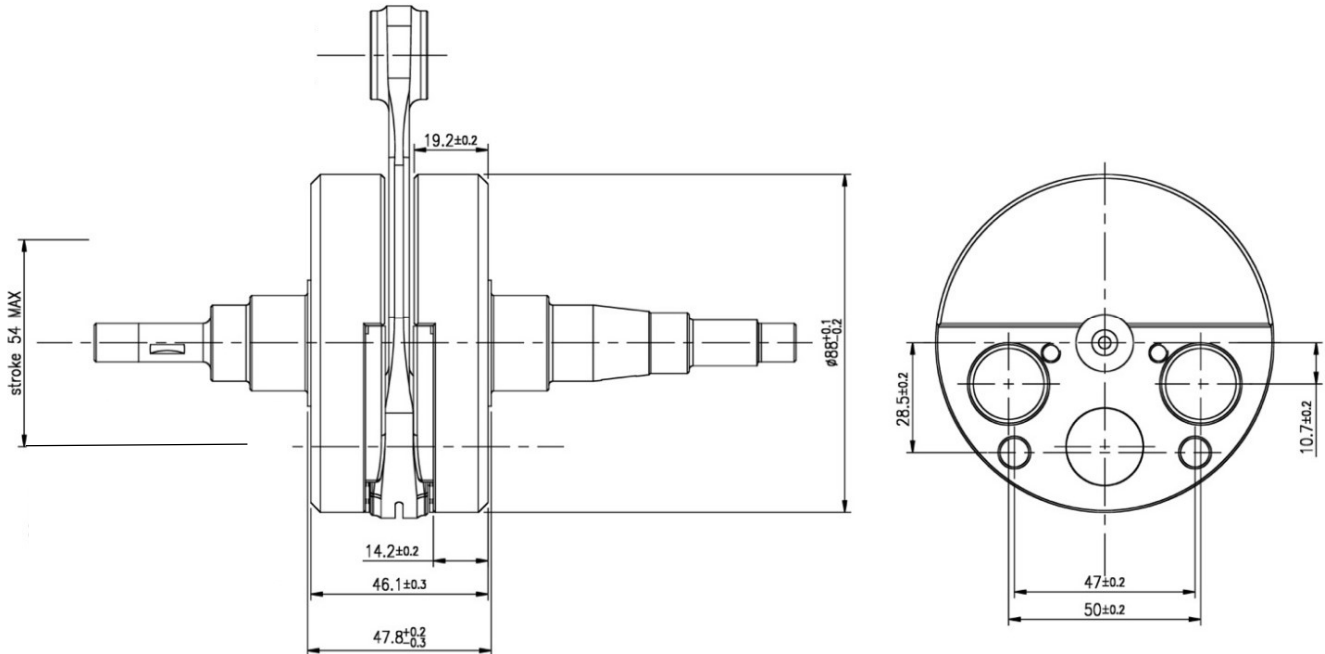

Peso – Weight – Poid
1.870g +/- 10g

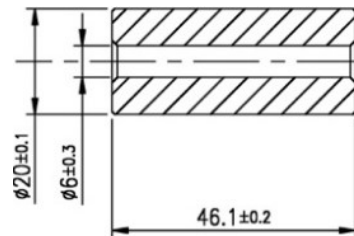

Peso – Weight – Poid
102g +/- 2g

ATTENTION

TUTTI LE PARTI DEL MOTORE DEVONO ESSERE ORIGINALI VORTEX ROK.

Né il motore né gli accessori possono essere in alcun modo modificati, per modifica si intende qualsiasi cambiamento di forma, contenuto o funzione, che rappresenti una condizione di differenza da quanto originariamente costruito (prodotto ed assemblato), inclusa l'aggiunta e/o l'asportazione di materiale. Tutte le misure dimensionali nei disegni tecnici si intendono in mm.

ALL THE ENGINE PARTS MUST BE ORIGINAL BY VORTEX ROK.

Neither engines nor accessories can be modified. By this we mean any shape, content or function changes which may differ from what originally produced (manufactured and assembled). Furthermore this includes any addition and /or removal of material.

All dimensions in the technical drawings are in mm.

TOUTES LES PARTS DU MOTEUR DOIVENT ETRE ORIGINALES VORTEX ROK.

Ni le moteur ni les accessoires peuvent être modifiés. Modification signifie tout changement de forme, de contenu ou de fonction, ce qui représente une condition de différence avec ce qui a été construit à l'origine (produit et assemblé). Ci-inclus aussi l'addition et/ou l'enlèvement de matériaux. Toutes les mesures dimensionnelles dans les dessins techniques sont en mm.

VLR / VLR-JUNIOR ROK 2025

PISTONE PISTON PISTON

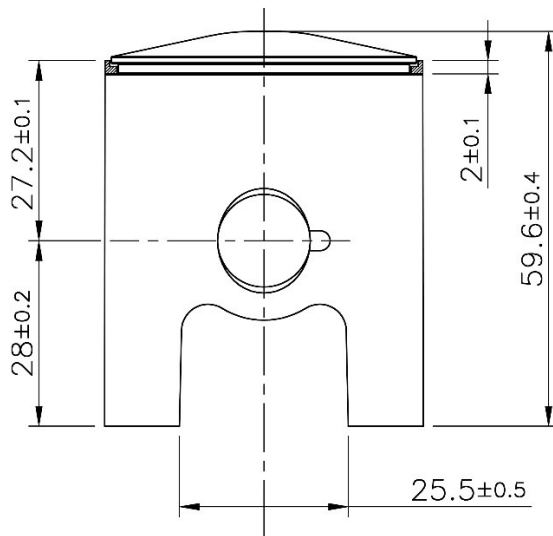

PESO – WEIGHT - POID
97 gr +/- 5 gr

SPINOTTO PISTONE PISTON PIN AXE DE PISTON

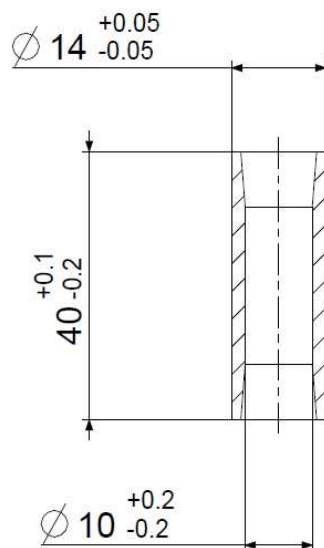

PESO – WEIGHT - POID
21 gr Min

ATTENTION

TUTTI LE PARTI DEL MOTORE DEVONO ESSERE ORIGINALI VORTEX ROK.

Né il motore né gli accessori possono essere in alcun modo modificati, per modifica si intende qualsiasi cambiamento di forma, contenuto o funzione, che rappresenti una condizione di differenza da quanto originariamente costruito (prodotto ed assemblato), inclusa l'aggiunta e/o l'asportazione di materiale. Tutte le misure dimensionali nei disegni tecnici si intendono in mm.

ALL THE ENGINE PARTS MUST BE ORIGINAL BY VORTEX ROK.

Neither engines nor accessories can be modified. By this we mean any shape, content or function changes which may differ from what originally produced (manufactured and assembled). Furthermore this includes any addition and /or removal of material.

All dimensions in the technical drawings are in mm.

TOUTES LES PARTS DU MOTEUR DOIVENT ETRE ORIGINALES VORTEX ROK.

Ni le moteur ni les accessoires peuvent être modifiés. Modification signifie tout changement de forme, de contenu ou de fonction, ce qui représente une condition de différence avec ce qui a été construit à l'origine (produit et assemblé). Ci-inclus aussi l'addition et/ou l'enlèvement de matériaux. Toutes les mesures dimensionnelles dans les dessins techniques sont en mm.

VLR / VLR-JUNIOR ROK 2025

VISTA INTERNA DEL CARTER E VISTA DI ASSIEME
 INTERIOR VIEW OF THE CRANKCASE AND ASSEMBLY VIEW
 VUE DE LA PARTIE INTERIEURE DU CARTER ET DESSIN D'ASSEMBLAGE

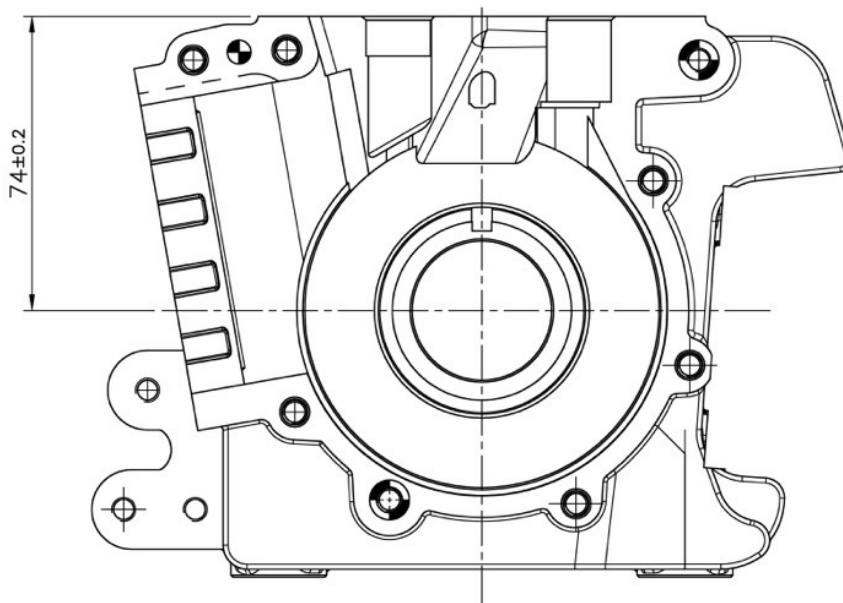

CUSCINETTI ALBERO MOTORE
 CRANKSHAFT BEARINGS
 PALIERS DE VILEBREQUIN

TIPO TYPE TIPE	DIMENSIONI DIMENSION DIMENSIONS	CARATTERISTICHE CHARACTERISTICS CARACTÉRISTIQUES
Marca libera/Free brand/ Marque libre 6205.C4	25x52x15mm	Sfere In Acciaio/ Steel Balls/ Billes D'acier 9

ATTENTION

TUTTI LE PARTI DEL MOTORE DEVONO ESSERE ORIGINALI VORTEX ROK.

Né il motore né gli accessori possono essere in alcun modo modificati, per modifica si intende qualsiasi cambiamento di forma, contenuto o funzione, che rappresenti una condizione di differenza da quanto originariamente costruito (prodotto ed assemblato), inclusa l'aggiunta e/o l'asportazione di materiale. Tutte le misure dimensionali nei disegni tecnici si intendono in mm.

ALL THE ENGINE PARTS MUST BE ORIGINAL BY VORTEX ROK.

Neither engines nor accessories can be modified. By this we mean any shape, content or function changes which may differ from what originally produced (manufactured and assembled). Furthermore this includes any addition and /or removal of material.

All dimensions in the technical drawings are in mm.

TOUTES LES PARTS DU MOTEUR DOIVENT ETRE ORIGINALES VORTEX ROK.

Ni le moteur ni les accessoires peuvent être modifiés. Modification signifie tout changement de forme, de contenu ou de fonction, ce qui représente une condition de différence avec ce qui a été construit à l'origine (produit et assemblé). Ci-inclus aussi l'addition et/ou l'enlèvement de matériaux. Toutes les mesures dimensionnelles dans les dessins techniques sont en mm.

VLR / VLR-JUNIOR ROK 2025

MARMITTA EXHAUST MUFFLER ECHAPEMENT

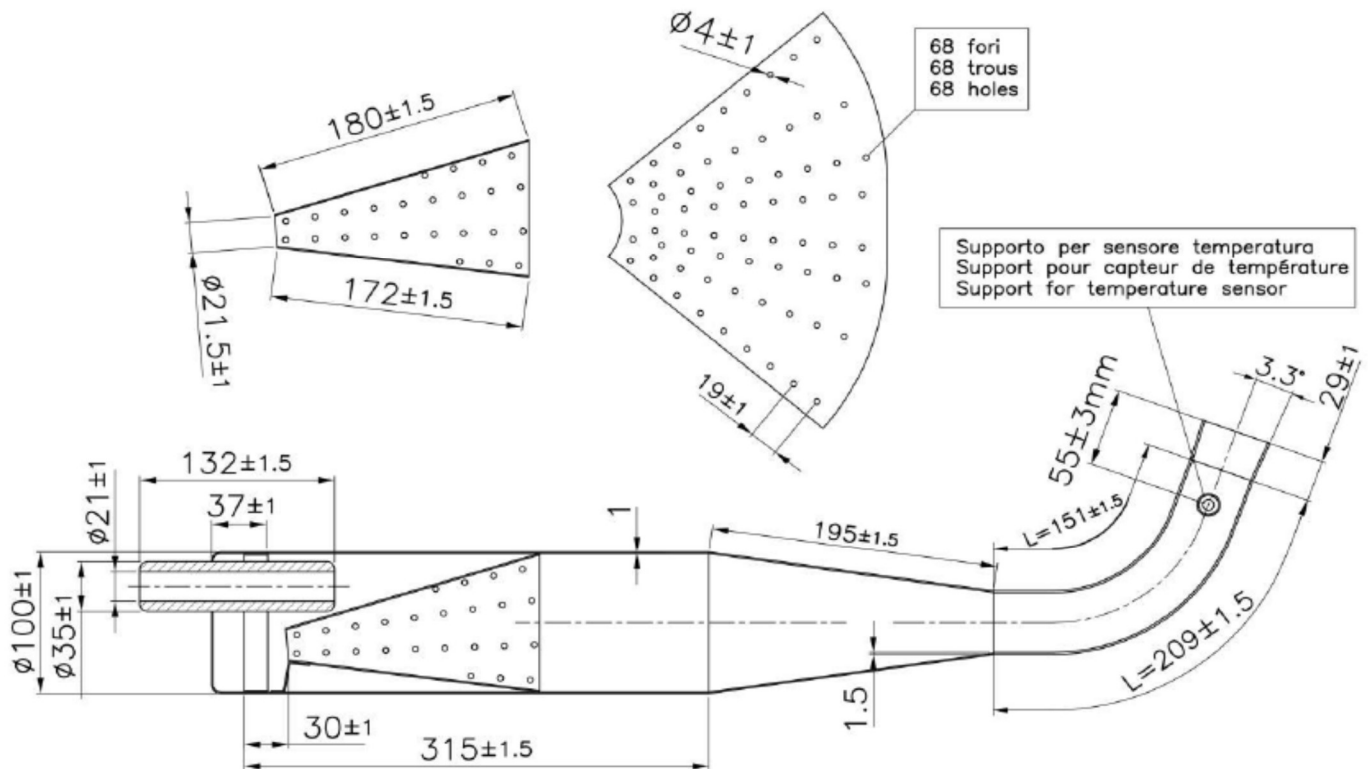

PESO MARMITTA
EXHAUST WEIGHT **1,990gr +/- 5%**
POID D'ECHAPEMENT

The end parts of the silencer must have two soldered pairs of lugs (one pair at the top and one pair at the bottom) to allow for fixing of seals by the Organizer so that the silencer may be opening during the competition.

ATTENTION

TUTTI LE PARTI DEL MOTORE DEVONO ESSERE ORIGINALI VORTEX ROK.

Né il motore né gli accessori possono essere in alcun modo modificati, per modifica si intende qualsiasi cambiamento di forma, contenuto o funzione, che rappresenti una condizione di differenza da quanto originariamente costruito (prodotto ed assemblato), inclusa l'aggiunta e/o l'asportazione di materiale. Tutte le misure dimensionali nei disegni tecnici si intendono in mm.

ALL THE ENGINE PARTS MUST BE ORIGINAL BY VORTEX ROK.

Neither engines nor accessories can be modified. By this we mean any shape, content or function changes which may differ from what originally produced (manufactured and assembled). Furthermore this includes any addition and /or removal of material.

All dimensions in the technical drawings are in mm.

TOUTES LES PARTS DU MOTEUR DOIVENT ETRE ORIGINALES VORTEX ROK.

Ni le moteur ni les accessoires peuvent être modifiés. Modification signifie tout changement de forme, de contenu ou de fonction, ce qui représente une condition de différence avec ce qui a été construit à l'origine (produit et assemblé). Ci-inclus aussi l'addition et/ou l'enlèvement de matériaux. Toutes les mesures dimensionnelles dans les dessins techniques sont en mm.

VLR / VLR-JUNIOR ROK 2025

COLLETTORE DI SCARICO EXHAUST MANIFOLD COLLECTEUR ECHAPPEMENT

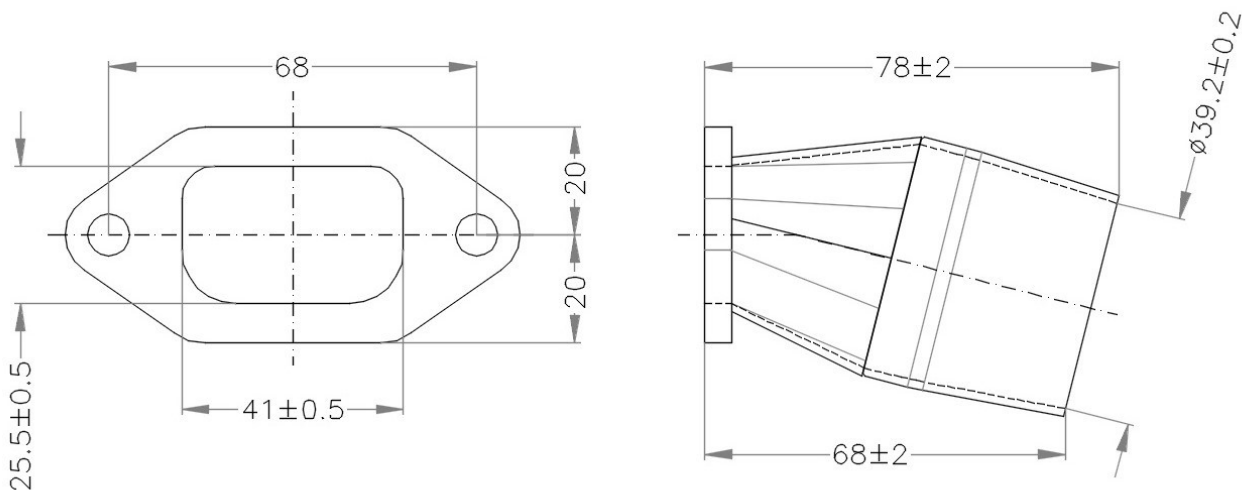

COLLETTORE DI SCARICO VLR JUNIOR EXHAUST MANIFOLD VLR JUNIOR COLLECTEUR ECHAPPEMENT VLR JUNIOR

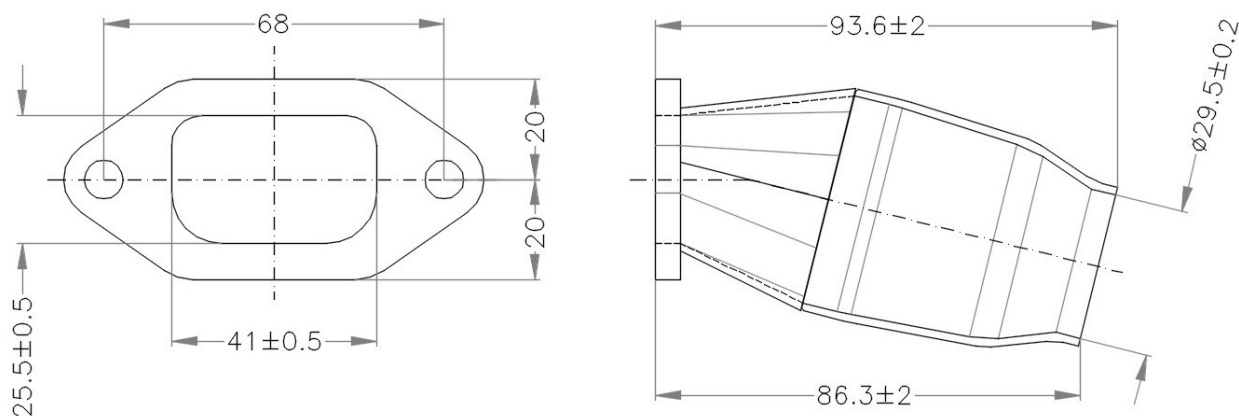

ATTENTION

TUTTI LE PARTI DEL MOTORE DEVONO ESSERE ORIGINALI VORTEX ROK.

Né il motore né gli accessori possono essere in alcun modo modificati, per modifica si intende qualsiasi cambiamento di forma, contenuto o funzione, che rappresenti una condizione di differenza da quanto originariamente costruito (prodotto ed assemblato), inclusa l'aggiunta e/o l'asportazione di materiale. Tutte le misure dimensionali nei disegni tecnici si intendono in mm.

ALL THE ENGINE PARTS MUST BE ORIGINAL BY VORTEX ROK.

Neither engines nor accessories can be modified. By this we mean any shape, content or function changes which may differ from what originally produced (manufactured and assembled). Furthermore this includes any addition and /or removal of material.

All dimensions in the technical drawings are in mm.

TOUTES LES PARTS DU MOTEUR DOIVENT ETRE ORIGINALES VORTEX ROK.

Ni le moteur ni les accessoires peuvent être modifiés. Modification signifie tout changement de forme, de contenu ou de fonction, ce qui représente une condition de différence avec ce qui a été construit à l'origine (produit et assemblé). Ci-inclus aussi l'addition et/ou l'enlèvement de matériaux. Toutes les mesures dimensionnelles dans les dessins techniques sont en mm.

VLR / VLR-JUNIOR ROK 2025

COLLETTORE DI SCARICO versione 2
EXHAUST MANIFOLD version 2
COLLECTEUR ECHAPPEMENT version 2

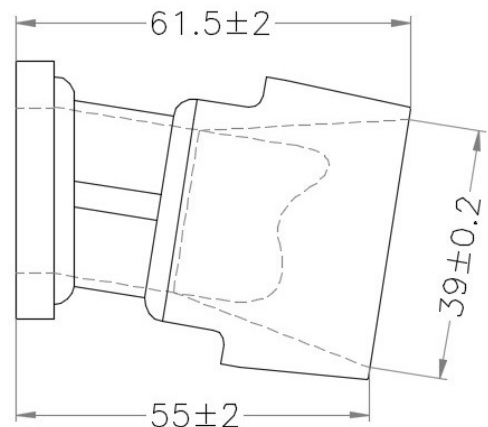
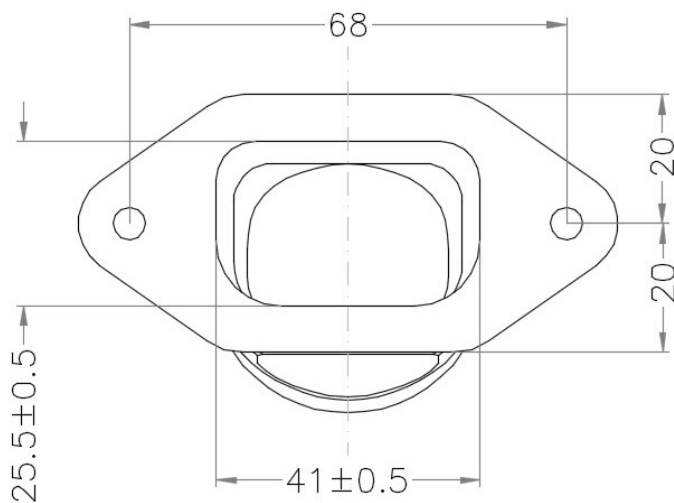
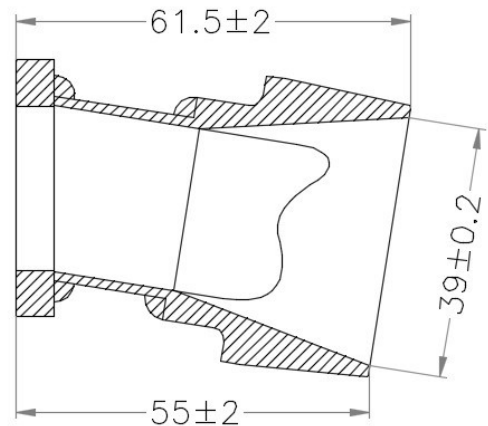
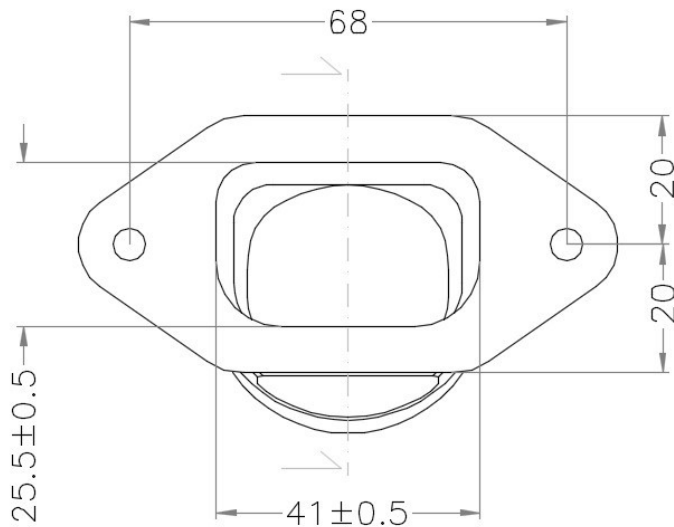

ATTENTION

TUTTI LE PARTI DEL MOTORE DEVONO ESSERE ORIGINALI VORTEX ROK.

Né il motore né gli accessori possono essere in alcun modo modificati, per modifica si intende qualsiasi cambiamento di forma, contenuto o funzione, che rappresenti una condizione di differenza da quanto originariamente costruito (prodotto ed assemblato), inclusa l'aggiunta e/o l'asportazione di materiale. Tutte le misure dimensionali nei disegni tecnici si intendono in mm.

ALL THE ENGINE PARTS MUST BE ORIGINAL BY VORTEX ROK.

Neither engines nor accessories can be modified. By this we mean any shape, content or function changes which may differ from what originally produced (manufactured and assembled). Furthermore this includes any addition and /or removal of material.

All dimensions in the technical drawings are in mm.

TOUTES LES PARTS DU MOTEUR DOIVENT ETRE ORIGINALES VORTEX ROK.

Ni le moteur ni les accessoires peuvent être modifiés. Modification signifie tout changement de forme, de contenu ou de fonction, ce qui représente une condition de différence avec ce qui a été construit à l'origine (produit et assemblé). Ci-inclus aussi l'addition et/ou l'enlèvement de matériaux. Toutes les mesures dimensionnelles dans les dessins techniques sont en mm.

VLR / VLR-JUNIOR ROK 2025

**DISEGNO DEL CONVOGLIATORE
DRAWING OF REED VALVE COVER
DESSIN DU COUVERCLE DE LA BOÎTE À CLAPETS**

OPTION 1

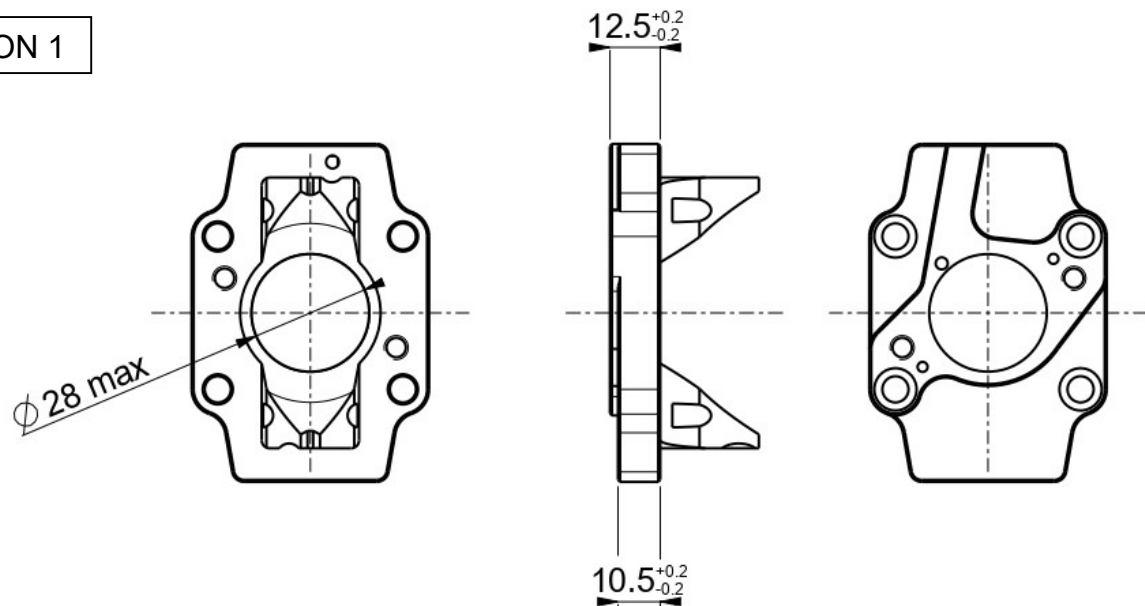

**DISEGNO DEL CONVOGLIATORE
DRAWING OF REED VALVE COVER
DESSIN DU COUVERCLE DE LA BOÎTE À CLAPETS**

OPTION 2

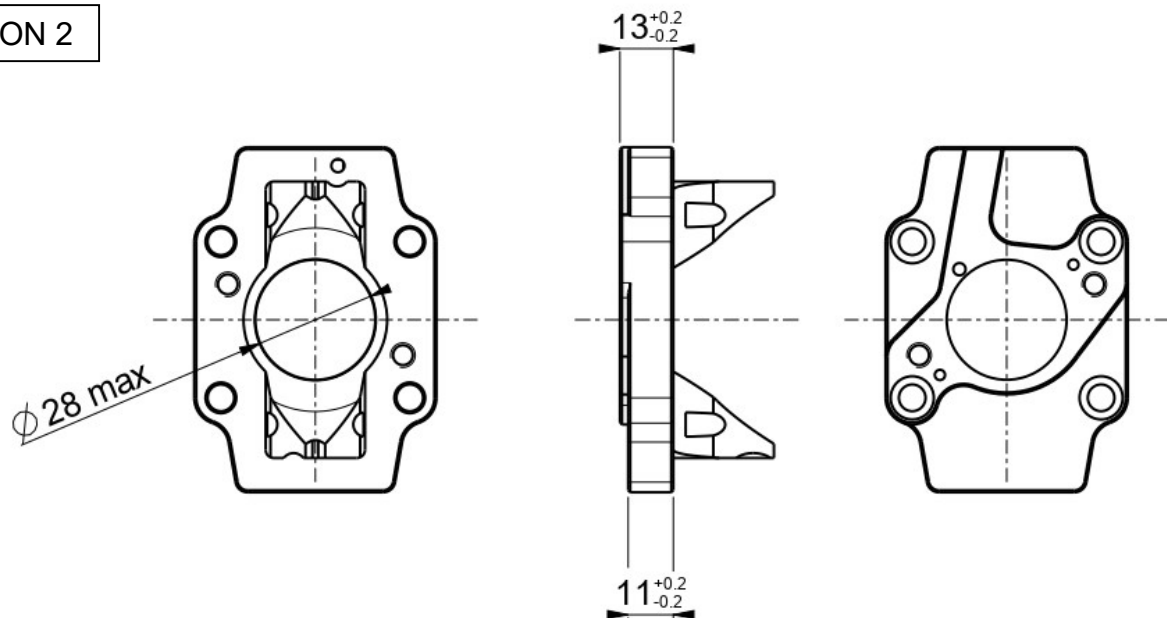

ATTENTION

TUTTI LE PARTI DEL MOTORE DEVONO ESSERE ORIGINALI VORTEX ROK.

Né il motore né gli accessori possono essere in alcun modo modificati, per modifica si intende qualsiasi cambiamento di forma, contenuto o funzione, che rappresenti una condizione di differenza da quanto originariamente costruito (prodotto ed assemblato), inclusa l'aggiunta e/o l'asportazione di materiale. Tutte le misure dimensionali nei disegni tecnici si intendono in mm.

ALL THE ENGINE PARTS MUST BE ORIGINAL BY VORTEX ROK.

Neither engines nor accessories can be modified. By this we mean any shape, content or function changes which may differ from what originally produced (manufactured and assembled). Furthermore this includes any addition and /or removal of material.

All dimensions in the technical drawings are in mm.

TOUTES LES PARTS DU MOTEUR DOIVENT ETRE ORIGINALES VORTEX ROK.

Ni le moteur ni les accessoires peuvent être modifiés. Modification signifie tout changement de forme, de contenu ou de fonction, ce qui représente une condition de différence avec ce qui a été construit à l'origine (produit et assemblé). Ci-inclus aussi l'addition et/ou l'enlèvement de matériaux. Toutes les mesures dimensionnelles dans les dessins techniques sont en mm.

VLR / VLR-JUNIOR ROK 2025

**DISEGNO DIMA DI CONTROLLO DEL CONVOGLIATORE
DRAWING OF THE CONTROL GEUGE OF THE REED VALVE COVER
DESSIN DU GABARIT POUR LA VERIFICATION DU COUVERCLE DE LA BOÎTE À CLAPETS**

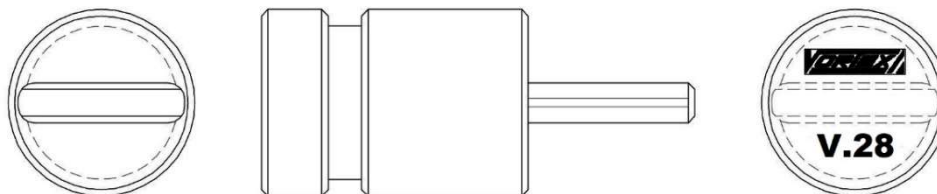

**DISEGNO TECNICO GUARNIZIONE TRA CRBURATORE E MOTORE
TECHNICAL DRAWING GASKET BETWEEN CARBURETTOR AND ENGINE
DESSIN TECHNIQUE JOINT ENTRE CARBURATEUR ET MOTEUR**

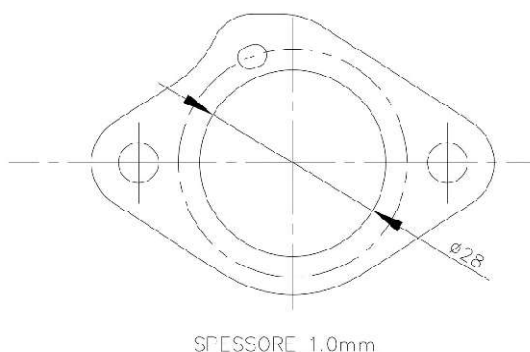

ATTENTION

TUTTI LE PARTI DEL MOTORE DEVONO ESSERE ORIGINALI VORTEX ROK.

Né il motore né gli accessori possono essere in alcun modo modificati, per modifica si intende qualsiasi cambiamento di forma, contenuto o funzione, che rappresenti una condizione di differenza da quanto originariamente costruito (prodotto ed assemblato), inclusa l'aggiunta e/o l'asportazione di materiale. Tutte le misure dimensionali nei disegni tecnici si intendono in mm.

ALL THE ENGINE PARTS MUST BE ORIGINAL BY VORTEX ROK.

Neither engines nor accessories can be modified. By this we mean any shape, content or function changes which may differ from what originally produced (manufactured and assembled). Furthermore this includes any addition and /or removal of material.

All dimensions in the technical drawings are in mm.

TOUTES LES PARTS DU MOTEUR DOIVENT ETRE ORIGINALES VORTEX ROK.

Ni le moteur ni les accessoires peuvent être modifiés. Modification signifie tout changement de forme, de contenu ou de fonction, ce qui représente une condition de différence avec ce qui a été construit à l'origine (produit et assemblé). Ci-inclus aussi l'addition et/ou l'enlèvement de matériaux. Toutes les mesures dimensionnelles dans les dessins techniques sont en mm.

VLR / VLR-JUNIOR ROK 2025

**DISEGNO DEL PACCO LAMELLARE E LAMELLE
DRAWING OF REED BLOCK AND REED VALVE
DESSIN DU PYRAMIDE CLAPETS ET CLAPETTES**

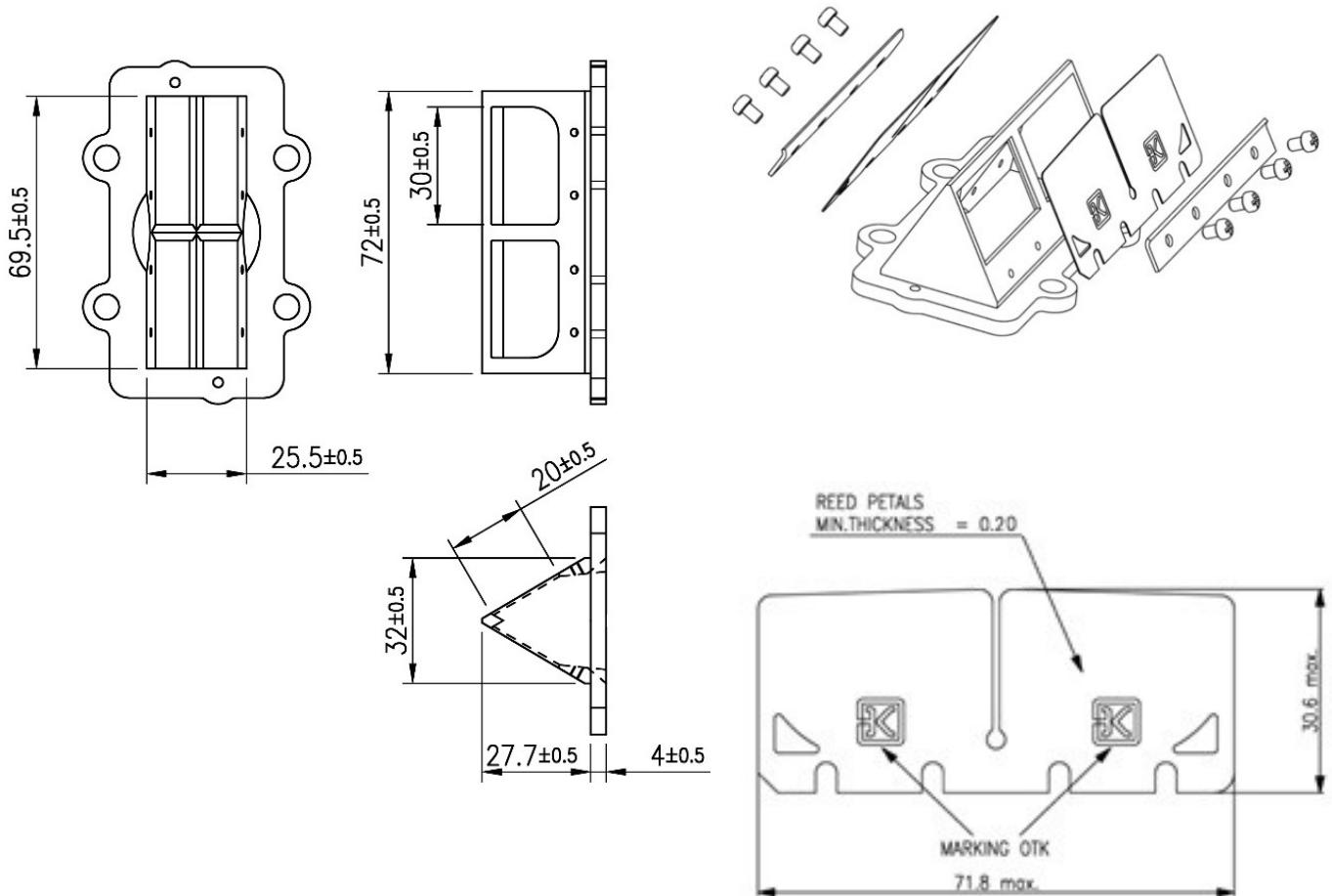

ATTENTION

TUTTI LE PARTI DEL MOTORE DEVONO ESSERE ORIGINALI VORTEX ROK.

Né il motore né gli accessori possono essere in alcun modo modificati, per modifica si intende qualsiasi cambiamento di forma, contenuto o funzione, che rappresenti una condizione di differenza da quanto originariamente costruito (prodotto ed assemblato), inclusa l'aggiunta e/o l'asportazione di materiale. Tutte le misure dimensionali nei disegni tecnici si intendono in mm.

ALL THE ENGINE PARTS MUST BE ORIGINAL BY VORTEX ROK.

Neither engines nor accessories can be modified. By this we mean any shape, content or function changes which may differ from what originally produced (manufactured and assembled). Furthermore this includes any addition and /or removal of material.

All dimensions in the technical drawings are in mm.

TOUTES LES PARTS DU MOTEUR DOIVENT ETRE ORIGINALES VORTEX ROK.

Ni le moteur ni les accessoires peuvent être modifiés. Modification signifie tout changement de forme, de contenu ou de fonction, ce qui représente une condition de différence avec ce qui a été construit à l'origine (produit et assemblé). Ci-inclus aussi l'addition et/ou l'enlèvement de matériaux. Toutes les mesures dimensionnelles dans les dessins techniques sont en mm.

VLR / VLR-JUNIOR ROK 2025

CAMPANA E ROTORE HOUSING AND ROTOR ROTOR ET BELL

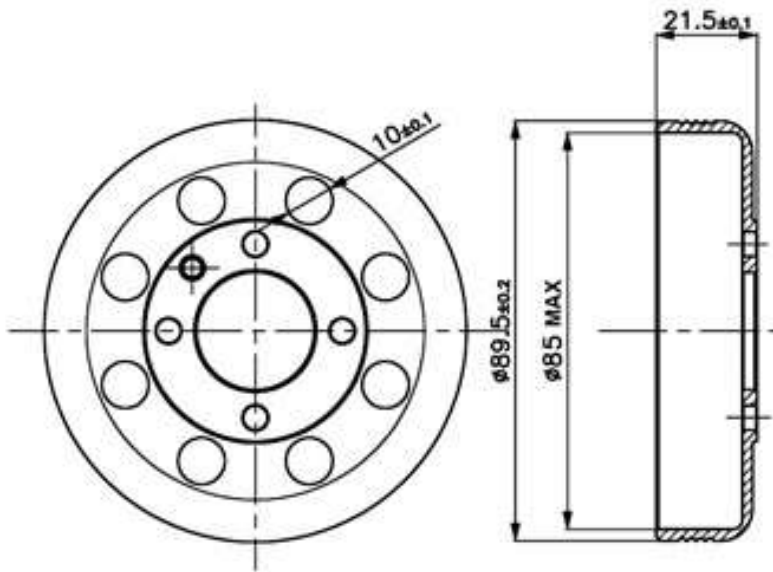

**PESO DELLA CAMPANA
WEIGHT OF CLUTCH HOUSING
POIDS DU BELL**

177gr +/- 5gr 177gr +/- 15gr

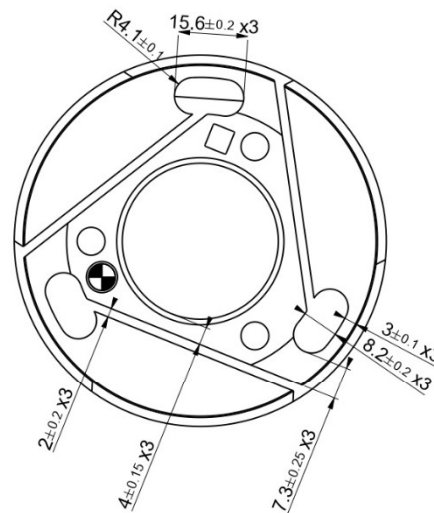
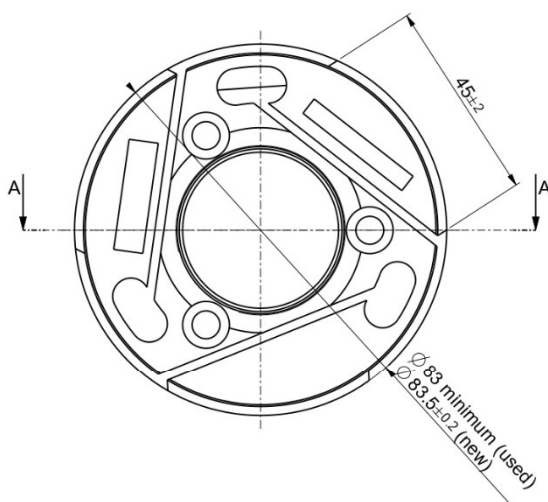

**PESO DEL ROTORE FRIZIONE
WEIGHT OF CLUTCH ROTOR
POIDS DU ROTOR EMBRAYAGE**

356 gr +/- 10gr 356 gr +/- 20gr

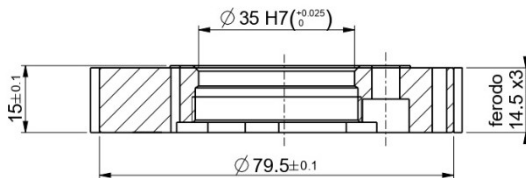

SEZIONE A-A

ATTENTION

TUTTI LE PARTI DEL MOTORE DEVONO ESSERE ORIGINALI VORTEX ROK.

Né il motore né gli accessori possono essere in alcun modo modificati, per modifica si intende qualsiasi cambiamento di forma, contenuto o funzione, che rappresenti una condizione di differenza da quanto originariamente costruito (prodotto ed assemblato), inclusa l'aggiunta e/o l'asportazione di materiale. Tutte le misure dimensionali nei disegni tecnici si intendono in mm.

ALL THE ENGINE PARTS MUST BE ORIGINAL BY VORTEX ROK.

Neither engines nor accessories can be modified. By this we mean any shape, content or function changes which may differ from what originally produced (manufactured and assembled). Furthermore this includes any addition and /or removal of material.

All dimensions in the technical drawings are in mm.

TOUTES LES PARTS DU MOTEUR DOIVENT ETRE ORIGINALES VORTEX ROK.

Ni le moteur ni les accessoires peuvent être modifiés. Modification signifie tout changement de forme, de contenu ou de fonction, ce qui représente une condition de différence avec ce qui a été construit à l'origine (produit et assemblé). Ci-inclus aussi l'addition et/ou l'enlèvement de matériaux. Toutes les mesures dimensionnelles dans les dessins techniques sont en mm.

VLR / VLR-JUNIOR ROK 2025

**ROTORE FRIZIONE COMPLETO CON INGRANAGGIO AVVIAMENTO
COMPL. CLUTCH ROTOR WITH STARTING GEAR
ROTOR EMBRAYAGE AVEC VITESSE DE DEMARRAGE**

NUMERO DI PARTI: 20

PARTS QUANTITY: 20

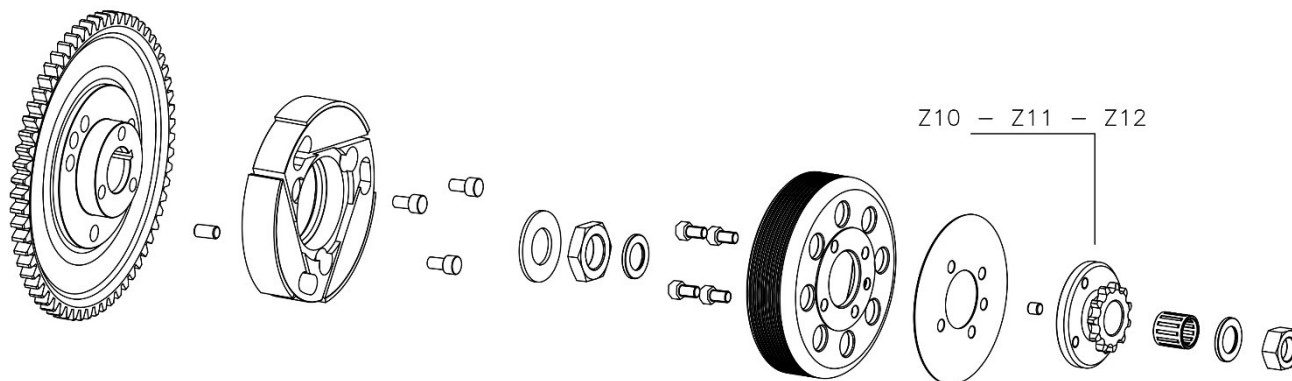

NUMERO DI PARTI: 20

PARTS QUANTITY: 20

NOMBRE DE PIÈCES COMPOSANTES: 20

PESO DELLA FRIZIONE COMPLETA DI INGRANAGGIO AVVIAMENTO E PROTEZIONE: ~~855 gr +/- 15gr~~ **855 gr +/- 30gr**

WEIGHT OF THE COMPLETE CLUTCH WITH STARTING GEAR AND PROTECTION

POIDS DE L'EMBRAYAGE COMPLETE AVEC ENGRENAGE DEMARRAGE ET PROTECTION

REGIME DI ATTACCO (MASSIMO) VERIFICABILE IN OGNI MOMENTO DELLA MANIFESTAZIONE

ENGAGEMENT SPEED (MAXIMUM) CAN BE VERIFIED IN EVERY MOMENT OF THE EVENT

VITESSE DE ENTRAINEMENT (MAXIMUM) VERIFIABLE DANS TOUS LES MOMENTS DE LA COURSE: **4000RPM**

ATTENTION

TUTTI LE PARTI DEL MOTORE DEVONO ESSERE ORIGINALI VORTEX ROK.

Né il motore né gli accessori possono essere in alcun modo modificati, per modifica si intende qualsiasi cambiamento di forma, contenuto o funzione, che rappresenti una condizione di differenza da quanto originariamente costruito (prodotto ed assemblato), inclusa l'aggiunta e/o l'asportazione di materiale. Tutte le misure dimensionali nei disegni tecnici si intendono in mm.

ALL THE ENGINE PARTS MUST BE ORIGINAL BY VORTEX ROK.

Neither engines nor accessories can be modified. By this we mean any shape, content or function changes which may differ from what originally produced (manufactured and assembled). Furthermore this includes any addition and /or removal of material.

All dimensions in the technical drawings are in mm.

TOUTES LES PARTS DU MOTEUR DOIVENT ETRE ORIGINALES VORTEX ROK.

Ni le moteur ni les accessoires peuvent être modifiés. Modification signifie tout changement de forme, de contenu ou de fonction, ce qui représente une condition de différence avec ce qui a été construit à l'origine (produit et assemblé). Ci-inclus aussi l'addition et/ou l'enlèvement de matériaux. Toutes les mesures dimensionnelles dans les dessins techniques sont en mm.

VLR / VLR-JUNIOR ROK 2025

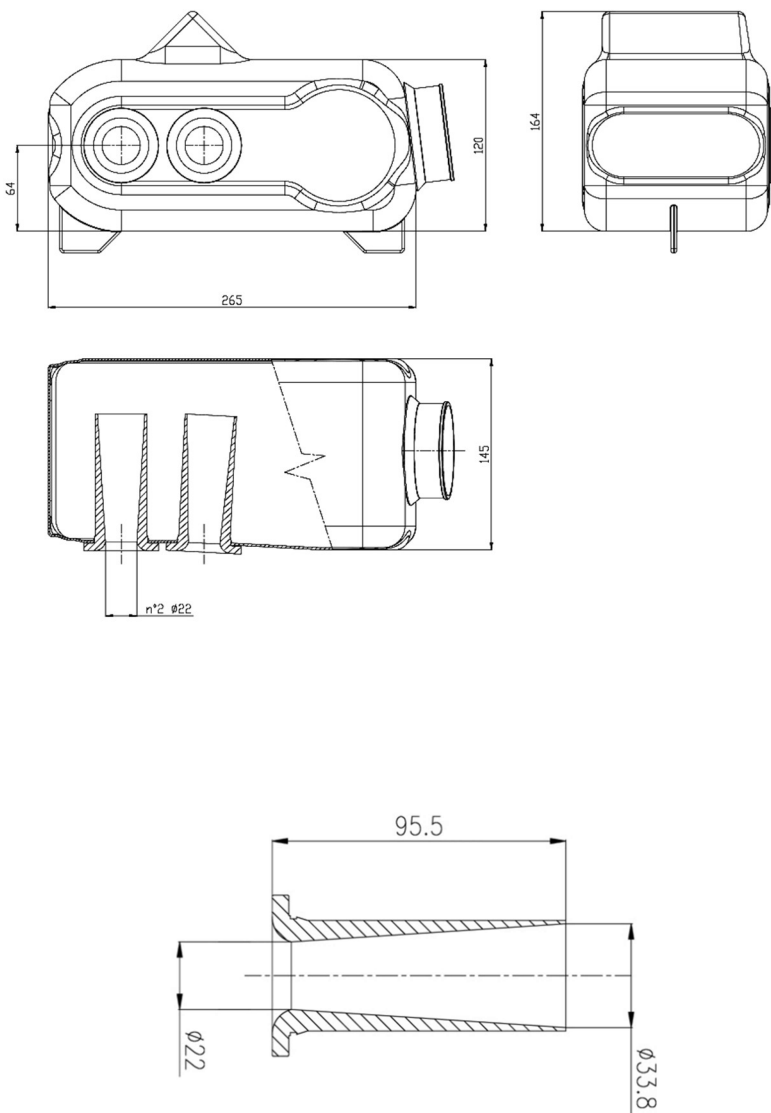
FILTRO D'ASPIRAZIONE INLET SILENCER SILENCIEUX D'ASPIRATION	
MODELLO, TIPO, MODEL TYPE MODELE, TYPE	VLR
	

ATTENTION

TUTTI LE PARTI DEL MOTORE DEVONO ESSERE ORIGINALI VORTEX ROK.

Né il motore né gli accessori possono essere in alcun modo modificati, per modifica si intende qualsiasi cambiamento di forma, contenuto o funzione, che rappresenti una condizione di differenza da quanto originariamente costruito (prodotto ed assemblato), inclusa l'aggiunta e/o l'asportazione di materiale. Tutte le misure dimensionali nei disegni tecnici si intendono in mm.

ALL THE ENGINE PARTS MUST BE ORIGINAL BY VORTEX ROK.

Neither engines nor accessories can be modified. By this we mean any shape, content or function changes which may differ from what originally produced (manufactured and assembled). Furthermore this includes any addition and /or removal of material.

All dimensions in the technical drawings are in mm.

TOUTES LES PARTS DU MOTEUR DOIVENT ETRE ORIGINALES VORTEX ROK.

Ni le moteur ni les accessoires peuvent être modifiés. Modification signifie tout changement de forme, de contenu ou de fonction, ce qui représente une condition de différence avec ce qui a été construit à l'origine (produit et assemblé). Ci-inclus aussi l'addition et/ou l'enlèvement de matériaux. Toutes les mesures dimensionnelles dans les dessins techniques sont en mm.

VLR / VLR-JUNIOR ROK 2025

FOTO ACCENSIONE SELETTA
PICTURES OF SELETTA IGNITION
PHOTO ALLUMAGE



CABLAGGIO AVVIAMENTO
STARTER WIRING
CABLE D'ALLUMAGE



**E' obbligatorio che il motore si accenda e si spenga con il sistema di avviamento on board.
I commissari tecnici potranno verificare il sistema di accensione e spegnimento in qualsiasi momento.**

**Engines shall be mandatory switched on and off by means of onboard starting system.
Technical stewards members shall check the on-off onboard system anytime.**

**Il est obligatoire que le moteur soit allumé et éteint au moyen du système de démarrage sur le chassis.
Les commissaires pourront effectuer des controles au système de démarrage et d'arrêt à tout moment.**

ATTENTION

TUTTI LE PARTI DEL MOTORE DEVONO ESSERE ORIGINALI VORTEX ROK.

Né il motore né gli accessori possono essere in alcun modo modificati, per modifica si intende qualsiasi cambiamento di forma, contenuto o funzione, che rappresenti una condizione di differenza da quanto originariamente costruito (prodotto ed assemblato), inclusa l'aggiunta e/o l'asportazione di materiale. Tutte le misure dimensionali nei disegni tecnici si intendono in mm.

ALL THE ENGINE PARTS MUST BE ORIGINAL BY VORTEX ROK.

Neither engines nor accessories can be modified. By this we mean any shape, content or function changes which may differ from what originally produced (manufactured and assembled). Furthermore this includes any addition and /or removal of material.

All dimensions in the technical drawings are in mm.

TOUTES LES PARTS DU MOTEUR DOIVENT ETRE ORIGINALES VORTEX ROK.

Ni le moteur ni les accessoires peuvent être modifiés. Modification signifie tout changement de forme, de contenu ou de fonction, ce qui représente une condition de différence avec ce qui a été construit à l'origine (produit et assemblé). Ci-inclus aussi l'addition et/ou l'enlèvement de matériaux. Toutes les mesures dimensionnelles dans les dessins techniques sont en mm.

VLR / VLR-JUNIOR ROK 2025

**DISEGNO DEL CABLAGGIO
DRAWING OF THE ELECTRIC SYSTEM ROUTING
CABLE IS FREE**

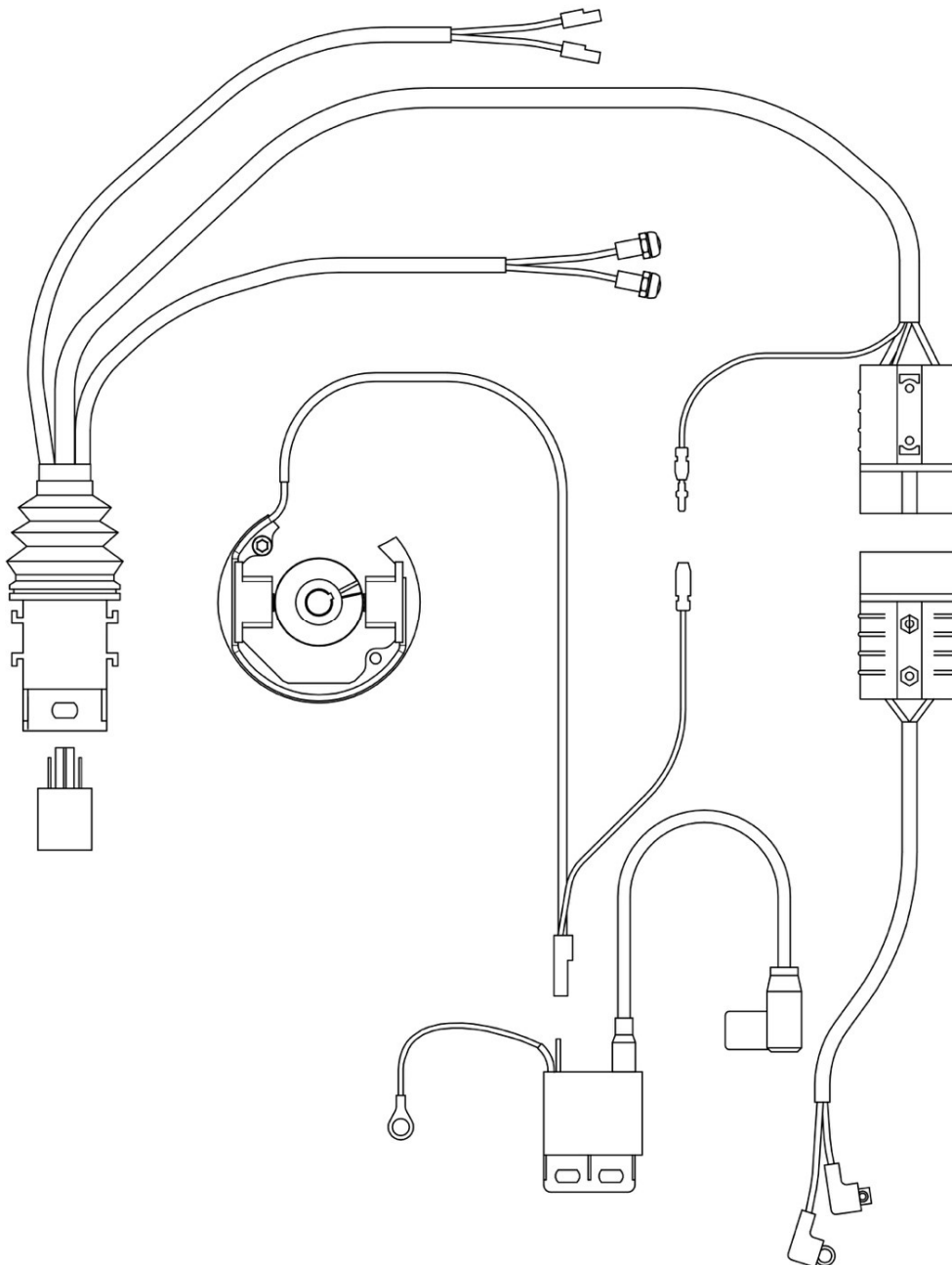

ATTENTION

TUTTI LE PARTI DEL MOTORE DEVONO ESSERE ORIGINALI VORTEX ROK.

Né il motore né gli accessori possono essere in alcun modo modificati, per modifica si intende qualsiasi cambiamento di forma, contenuto o funzione, che rappresenti una condizione di differenza da quanto originariamente costruito (prodotto ed assemblato), inclusa l'aggiunta e/o l'asportazione di materiale. Tutte le misure dimensionali nei disegni tecnici si intendono in mm.

ALL THE ENGINE PARTS MUST BE ORIGINAL BY VORTEX ROK.

Neither engines nor accessories can be modified. By this we mean any shape, content or function changes which may differ from what originally produced (manufactured and assembled). Furthermore this includes any addition and /or removal of material.

All dimensions in the technical drawings are in mm.

TOUTES LES PARTS DU MOTEUR DOIVENT ETRE ORIGINALES VORTEX ROK.

Ni le moteur ni les accessoires peuvent être modifiés. Modification signifie tout changement de forme, de contenu ou de fonction, ce qui représente une condition de différence avec ce qui a été construit à l'origine (produit et assemblé). Ci-inclus aussi l'addition et/ou l'enlèvement de matériaux. Toutes les mesures dimensionnelles dans les dessins techniques sont en mm.

VLR / VLR-JUNIOR ROK 2025

**MARCHIATURA DELLA TESTA E CAMERA DI COMBUSTIONE
MARKING OF THE CYLINDERHEAD AND COMBUSTION CHAMBER
MARQUAGE DU CULASSE ET CHAMBRE DE COMBUSTION**

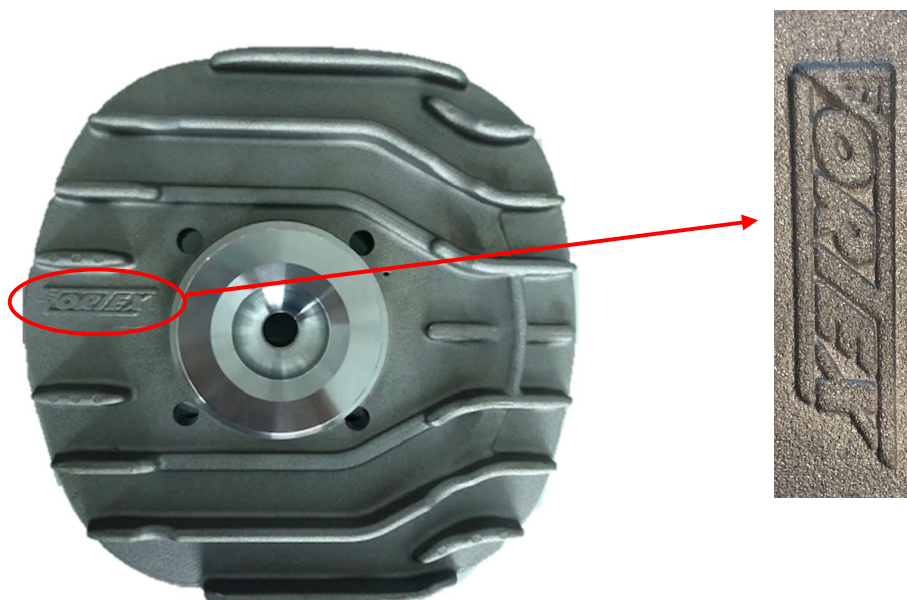

**MARCHIATURA DELLA BASE CILINDRO
MARKING OF CYLINDER BASE
MARQUAGE DU PIED DU CYLINDRE**

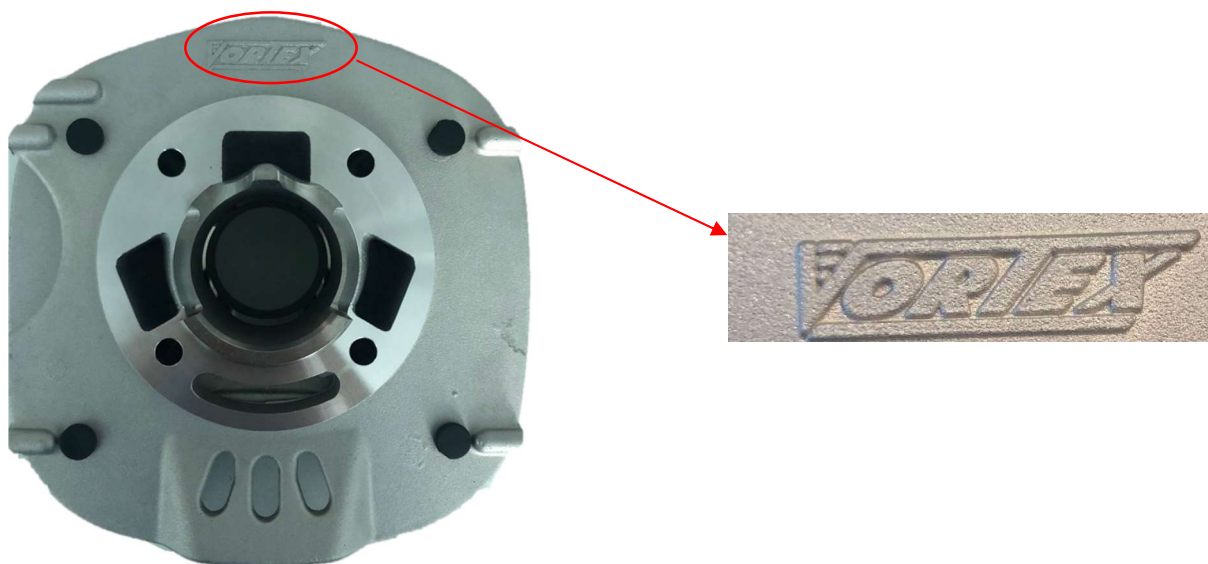

TUTTI LE PARTI DEL MOTORE DEVONO ESSERE ORIGINALI VORTEX ROK.

Né il motore né gli accessori possono essere in alcun modo modificati, per modifica si intende qualsiasi cambiamento di forma, contenuto o funzione, che rappresenti una condizione di differenza da quanto originariamente costruito (prodotto ed assemblato), inclusa l'aggiunta e/o l'asportazione di materiale. Tutte le misure dimensionali nei disegni tecnici si intendono in mm.

ALL THE ENGINE PARTS MUST BE ORIGINAL BY VORTEX ROK.

Neither engines nor accessories can be modified. By this we mean any shape, content or function changes which may differ from what originally produced (manufactured and assembled). Furthermore this includes any addition and /or removal of material.

All dimensions in the technical drawings are in mm.

TOUTES LES PARTS DU MOTEUR DOIVENT ETRE ORIGINALES VORTEX ROK.

Ni le moteur ni les accessoires peuvent être modifiés. Modification signifie tout changement de forme, de contenu ou de fonction, ce qui représente une condition de différence avec ce qui a été construit à l'origine (produit et assemblé). Ci-inclus aussi l'addition et/ou l'enlèvement de matériaux. Toutes les mesures dimensionnelles dans les dessins techniques sont en mm.

ATTENTION

VLR / VLR-JUNIOR ROK 2025

MARCHIATURA DEI CARTER MARKING OF THE CRANKCASE MARQUAGE DU CARTER

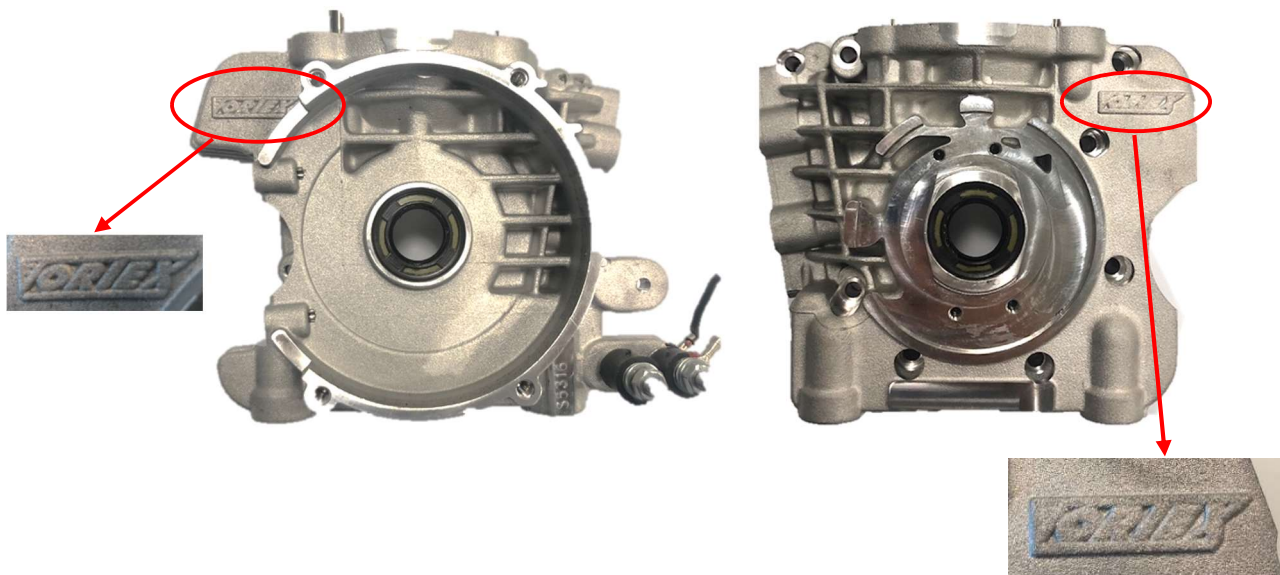

MARCHIATURA DELL'ALBERO MOTORE MARKING OF CRANKSHAFT MARQUAGE DU VILEBREQUIN



ATTENTION

TUTTI LE PARTI DEL MOTORE DEVONO ESSERE ORIGINALI VORTEX ROK.

Né il motore né gli accessori possono essere in alcun modo modificati, per modifica si intende qualsiasi cambiamento di forma, contenuto o funzione, che rappresenti una condizione di differenza da quanto originariamente costruito (prodotto ed assemblato), inclusa l'aggiunta e/o l'asportazione di materiale. Tutte le misure dimensionali nei disegni tecnici si intendono in mm.

ALL THE ENGINE PARTS MUST BE ORIGINAL BY VORTEX ROK.

Neither engines nor accessories can be modified. By this we mean any shape, content or function changes which may differ from what originally produced (manufactured and assembled). Furthermore this includes any addition and /or removal of material.

All dimensions in the technical drawings are in mm.

TOUTES LES PARTS DU MOTEUR DOIVENT ETRE ORIGINALES VORTEX ROK.

Ni le moteur ni les accessoires peuvent être modifiés. Modification signifie tout changement de forme, de contenu ou de fonction, ce qui représente une condition de différence avec ce qui a été construit à l'origine (produit et assemblé). Ci-inclus aussi l'addition et/ou l'enlèvement de matériaux. Toutes les mesures dimensionnelles dans les dessins techniques sont en mm.

VLR / VLR-JUNIOR ROK 2025

<p>FOTO DEL PISTONE PICTURE OF THE PISTON PHOTO DU PISTON</p>	<p>MARCHIATURA DELLA BIELLA MARKING OF THE CONROD MARQUAGE DE LA BIELLE</p>
	

MARCHIATURA DEL PISTONE
MARKING OF THE PISTON
MARQUAGE DU PISTON

**Obbligatorio avere il pistone marchiato VORTEX in fusione come da figura.
Mandatory to have the brand VORTEX cast piston as shown in the picture.
Obligatoire d' avoir le piston en fonte marque VORTEX comme sur la figure.**

	
---	--

<p>ATTENTION</p>	<p><u>TUTTI LE PARTI DEL MOTORE DEVONO ESSERE ORIGINALI VORTEX ROK.</u> Né il motore né gli accessori possono essere in alcun modo modificati, per modifica si intende qualsiasi cambiamento di forma, contenuto o funzione, che rappresenti una condizione di differenza da quanto originariamente costruito (prodotto ed assemblato), inclusa l'aggiunta e/o l'asportazione di materiale. Tutte le misure dimensionali nei disegni tecnici si intendono in mm.</p> <p><u>ALL THE ENGINE PARTS MUST BE ORIGINAL BY VORTEX ROK.</u> Neither engines nor accessories can be modified. By this we mean any shape, content or function changes which may differ from what originally produced (manufactured and assembled). Furthermore this includes any addition and /or removal of material. All dimensions in the technical drawings are in mm.</p> <p><u>TOUTES LES PARTS DU MOTEUR DOIVENT ETRE ORIGINALES VORTEX ROK.</u> Ni le moteur ni les accessoires peuvent être modifiés. Modification signifie tout changement de forme, de contenu ou de fonction, ce qui représente une condition de différence avec ce qui a été construit à l'origine (produit et assemblé). Ci-inclus aussi l'addition et/ou l'enlèvement de matériaux. Toutes les mesures dimensionnelles dans les dessins techniques sont en mm.</p>
-------------------------	--

VLR / VLR-JUNIOR ROK 2025

FOTO E MARCHIATURA DELLA MARMITTA
PHOTO AND MARKING OF THE EXHAUST
PHOTO ET MARQUAGE DE L'ÉCHAPPEMENT



ATTENTION

TUTTI LE PARTI DEL MOTORE DEVONO ESSERE ORIGINALI VORTEX ROK.

Né il motore né gli accessori possono essere in alcun modo modificati, per modifica si intende qualsiasi cambiamento di forma, contenuto o funzione, che rappresenti una condizione di differenza da quanto originariamente costruito (prodotto ed assemblato), inclusa l'aggiunta e/o l'asportazione di materiale. Tutte le misure dimensionali nei disegni tecnici si intendono in mm.

ALL THE ENGINE PARTS MUST BE ORIGINAL BY VORTEX ROK.

Neither engines nor accessories can be modified. By this we mean any shape, content or function changes which may differ from what originally produced (manufactured and assembled). Furthermore this includes any addition and /or removal of material.

All dimensions in the technical drawings are in mm.

TOUTES LES PARTS DU MOTEUR DOIVENT ETRE ORIGINALES VORTEX ROK.

Ni le moteur ni les accessoires peuvent être modifiés. Modification signifie tout changement de forme, de contenu ou de fonction, ce qui représente une condition de différence avec ce qui a été construit à l'origine (produit et assemblé). Ci-inclus aussi l'addition et/ou l'enlèvement de matériaux. Toutes les mesures dimensionnelles dans les dessins techniques sont en mm.

VLR / VLR-JUNIOR ROK 2025

FOTO E MARCHIATURA DEL CONVOGLIATORE
 PICTURES AND MARKING OF REED VALVE COVER
 PHOTO ET MARQUAGE DU COUVERCLE DE LA BOÎTE À CLAPETS



FOTO E MARCHIATURA DEL PIGNONE E DELLA CAMPANA FRIZIONE
 PICTURES AND MARKING OF PIGNION AND CLUTCH DRUM
 PHOTO ET MARQUAGE DU PIGNON E LA CLOCHE D'EMBRAYAGE



ATTENTION

TUTTI LE PARTI DEL MOTORE DEVONO ESSERE ORIGINALI VORTEX ROK.

Né il motore né gli accessori possono essere in alcun modo modificati, per modifica si intende qualsiasi cambiamento di forma, contenuto o funzione, che rappresenti una condizione di differenza da quanto originariamente costruito (prodotto ed assemblato), inclusa l'aggiunta e/o l'asportazione di materiale. Tutte le misure dimensionali nei disegni tecnici si intendono in mm.

ALL THE ENGINE PARTS MUST BE ORIGINAL BY VORTEX ROK.

Neither engines nor accessories can be modified. By this we mean any shape, content or function changes which may differ from what originally produced (manufactured and assembled). Furthermore this includes any addition and /or removal of material.

All dimensions in the technical drawings are in mm.

TOUTES LES PARTS DU MOTEUR DOIVENT ETRE ORIGINALES VORTEX ROK.

Ni le moteur ni les accessoires peuvent être modifiés. Modification signifie tout changement de forme, de contenu ou de fonction, ce qui représente une condition de différence avec ce qui a été construit à l'origine (produit et assemblé). Ci-inclus aussi l'addition et/ou l'enlèvement de matériaux. Toutes les mesures dimensionnelles dans les dessins techniques sont en mm.

VLR / VLR-JUNIOR ROK 2025

FOTO E MARCHIATURA DEL CORPO FRIZIONE RUOTA DENTATA DI AVVIAMENTO
 PICTURES AND MARKING OF CLUTCH BODY AND STARTER WHEELS
 PHOTO ET MARQUAGE DE L'EMBRAYAGE E ROUE D'EMBRAYAGE



FOTO E TIMBRATURA DELLE LAMELLE
 PICTURES AND MARKING OF THE REEDS
 PHOTO ET MARQUAGE DU CLAPETTES



LE LAMELLE IN CARBONIO DEVONO ESSERE ENTRAMBE, OBBLIGATORIAMENTE, ORIGINALI E MARCHIATE OTK COME INDICATO IN FOTO, CON SPESSORE MINIMO DI 0,20mm.

CARBON FIBER REED PETALS MUST BE BOTH, MANDATORY, ORIGINAL AND BRANDED OTK AS SHOWN IN THE PICTURE, MINIMUM THICKNESS 0,20mm.

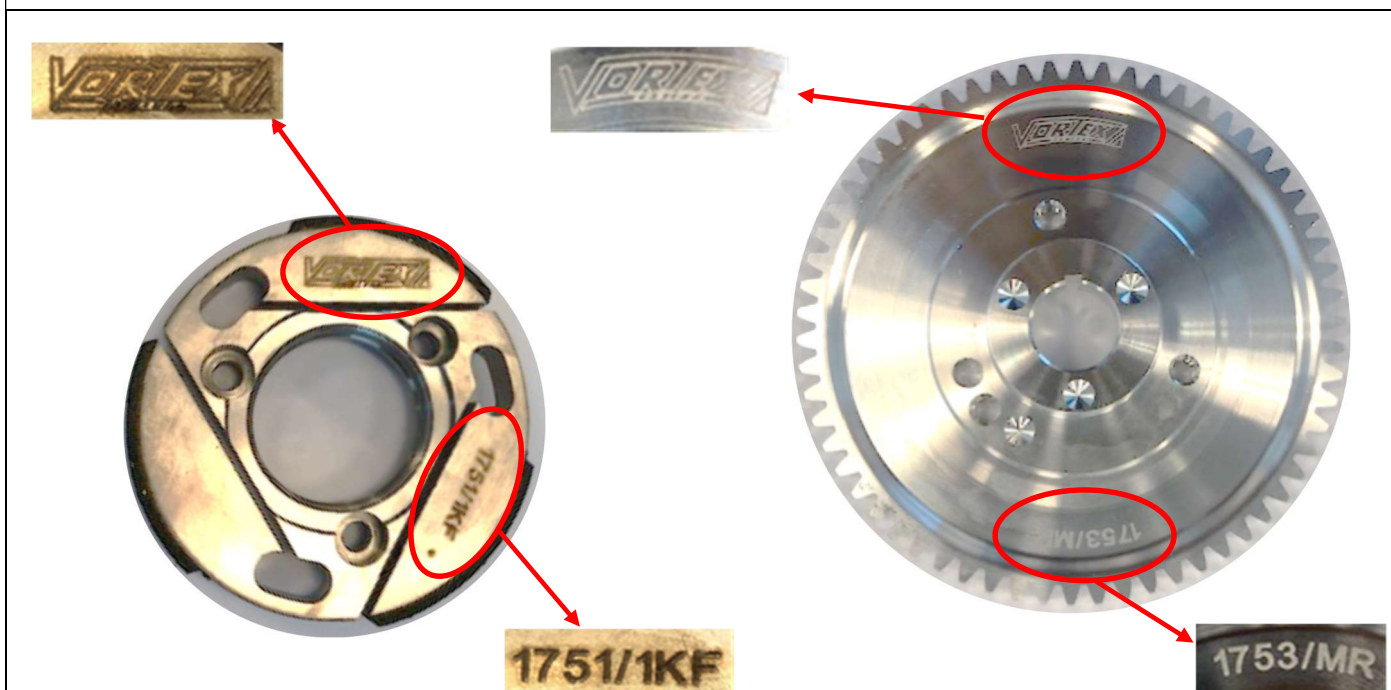
LES CLAPETTES DE CARBON DOIVENT ÊTRE LES DEUX, ORIGINALEMENT ET MARQUES OTK COMME INDIQUÉ SUR LA FIGURE, AVEC UNE ÉPAISSEUR MINIMALE DE 0,20 mm.

TUTTI LE PARTI DEL MOTORE DEVONO ESSERE ORIGINALI VORTEX ROK.

Né il motore né gli accessori possono essere in alcun modo modificati, per modifica si intende qualsiasi cambiamento di forma, contenuto o funzione, che rappresenti una condizione di differenza da quanto originariamente costruito (prodotto ed assemblato), inclusa l'aggiunta e/o l'asportazione di materiale. Tutte le misure dimensionali nei disegni tecnici si intendono in mm.

ALL THE ENGINE PARTS MUST BE ORIGINAL BY VORTEX ROK.

Neither engines nor accessories can be modified. By this we mean any shape, content or function changes which may differ from what originally produced (manufactured and assembled). Furthermore this includes any addition and /or removal of material.

All dimensions in the technical drawings are in mm.

TOUTES LES PARTS DU MOTEUR DOIVENT ÊTRE ORIGINALES VORTEX ROK.

Ni le moteur ni les accessoires peuvent être modifiés. Modification signifie tout changement de forme, de contenu ou de fonction, ce qui représente une condition de différence avec ce qui a été construit à l'origine (produit et assemblé). Ci-inclus aussi l'addition et/ou l'enlèvement de matériaux. Toutes les mesures dimensionnelles dans les dessins techniques sont en mm.

ATTENTION

VLR / VLR-JUNIOR ROK 2025

FOTO E TIMBRATURA DEL COLLETTORE DI SCARICO versione 2
PICTURES AND MARKING OF MANIFOLD version 2
PHOTO ET MARQUAGE DU COLLECTEUR ECHAPPEMENT version 2



ATTENTION

TUTTI LE PARTI DEL MOTORE DEVONO ESSERE ORIGINALI VORTEX ROK.

Né il motore né gli accessori possono essere in alcun modo modificati, per modifica si intende qualsiasi cambiamento di forma, contenuto o funzione, che rappresenti una condizione di differenza da quanto originariamente costruito (prodotto ed assemblato), inclusa l'aggiunta e/o l'asportazione di materiale. Tutte le misure dimensionali nei disegni tecnici si intendono in mm.

ALL THE ENGINE PARTS MUST BE ORIGINAL BY VORTEX ROK.

Neither engines nor accessories can be modified. By this we mean any shape, content or function changes which may differ from what originally produced (manufactured and assembled). Furthermore this includes any addition and /or removal of material.

All dimensions in the technical drawings are in mm.

TOUTES LES PARTS DU MOTEUR DOIVENT ETRE ORIGINALES VORTEX ROK.

Ni le moteur ni les accessoires peuvent être modifiés. Modification signifie tout changement de forme, de contenu ou de fonction, ce qui représente une condition de différence avec ce qui a été construit à l'origine (produit et assemblé). Ci-inclus aussi l'addition et/ou l'enlèvement de matériaux. Toutes les mesures dimensionnelles dans les dessins techniques sont en mm.

VLR ROK 2025

1. Fuel System:

- a. All fuel system components must be utilized as supplied.
- b. No additional components are permitted.
- c. Any fuel filter must be fixed between the carburetor and the fuel tank, and no additional component are permitted.

2. Carburetor:

- a. The only allowed Tillotson HW-38A .
- b. Replacement parts must be of the same type and size as originally supplied.

3. Air Box:

- a. Foam air filter insert is optional.
- b. Air box clamps MUST be tight.
- c. Air box must not contain any additional holes.
- d. No external form of air ducts forcing air inside of air box is permitted.
- e. Air box must be secured completely after each track event otherwise last place position is given.
- f. Plastic protection under rain conditions is allowed.

4. Coil:

- a. Must be mounted to the engine.
- b. Must use coil wire as supplied.

5. Wiring Harness:

- a. Wire Harness is open and optional.

6. Battery:

- a. Battery may as supplied or any lightweight battery as long as it is mounted securely in the supplied battery box. No battery or battery box is also allowed.
- b. Battery must fit in supplied battery box.

- c. A secondary battery is allowed to power data systems only: Mychron, Unipro, Alfano, etc.

6.5 Spark Plug:

- a. Only the following plugs allowed:
 - i. NGK B/BR 9EG & 10EG.
 - ii. Must be original and no modification is allowed. (Changing the spark plug gap is allowed).
- b. Original supplied spark plug washer or head temperature gauge sender must be in place.
- c. Spark Plug Cap must be as supplied.

7. Exhaust Pipe:

- a. No treatment of any kind.
- b. No sand blasting is allowed.
- c. No form of thermo wrapping is allowed.
- d. Internal dimensions may not be altered because of rust.
- e. No modifications to silencer end cap.
- f. No major likings.
- g. Exhaust temperature sensor:
 - i. One exhaust temperature sensor is allowed.
 - ii. One hole only can be drilled on the exhaust pipe for sensor.
 - iii. No specific location is required for the exhaust temperature sensor.
 - iv. Any hole not being used must be completely plugged if exhaust sensor is not being used.
 - v. Exhaust **MUST** remain intact, as provided by the manufacturer. No cracks and/or welding is permitted.

8. Exhaust Header:

- a. As per Homologation File.
- b. Headers cannot be cracked or leaking.
- c. A go-no go gauge will be used to control headers. It is allowed to clean the restrictor headers with scotch-brite or solvent.

9. Clutch:

- a. Clutch components **MUST** not contain significant amounts of any kind of oil or grease.
- b. It is NOT mandatory, but recommended to use the dust cover of the clutch bell.

10. Ignition Timing:

- a. Ignition timing non-tech.

11. External Modifications:

- a. Any modification clearly not called out inside this document is not to be taken as legally acceptable.

12. Vortex

- a. **Engine sprocket:** Vortex 10T, 11T, 12T, 13T.
- b. Cylinder base gasket thickness is non-tech and could be changed to adjust the port timing.
- c. Copper head gasket to adjust squish is allowed, thickness is non-tech.
- d. The shape of the combustion chamber must be original.

13. Fuel and Oil

- a. Spec racing fuel for all Rok Categories is Sunoco STANDARD 110.
- b. Spec racing oil is Motul 2T. No other oil or additives are allowed.

14. Engine Eligibility

- a. Canadian license holders must use Engines with a Canadian serial numbers.
- b. International drivers may use non-Canadian engines provided they comply with the Vortex Canada technical regulations
- c. Engine eligibility list will be available on-line <https://goodwoodkartways.com/vortexcanada/> and from tech director. If engine is not on the list you will need submit proof of Candian purchase to tech director.

VLR PORT GAUGE

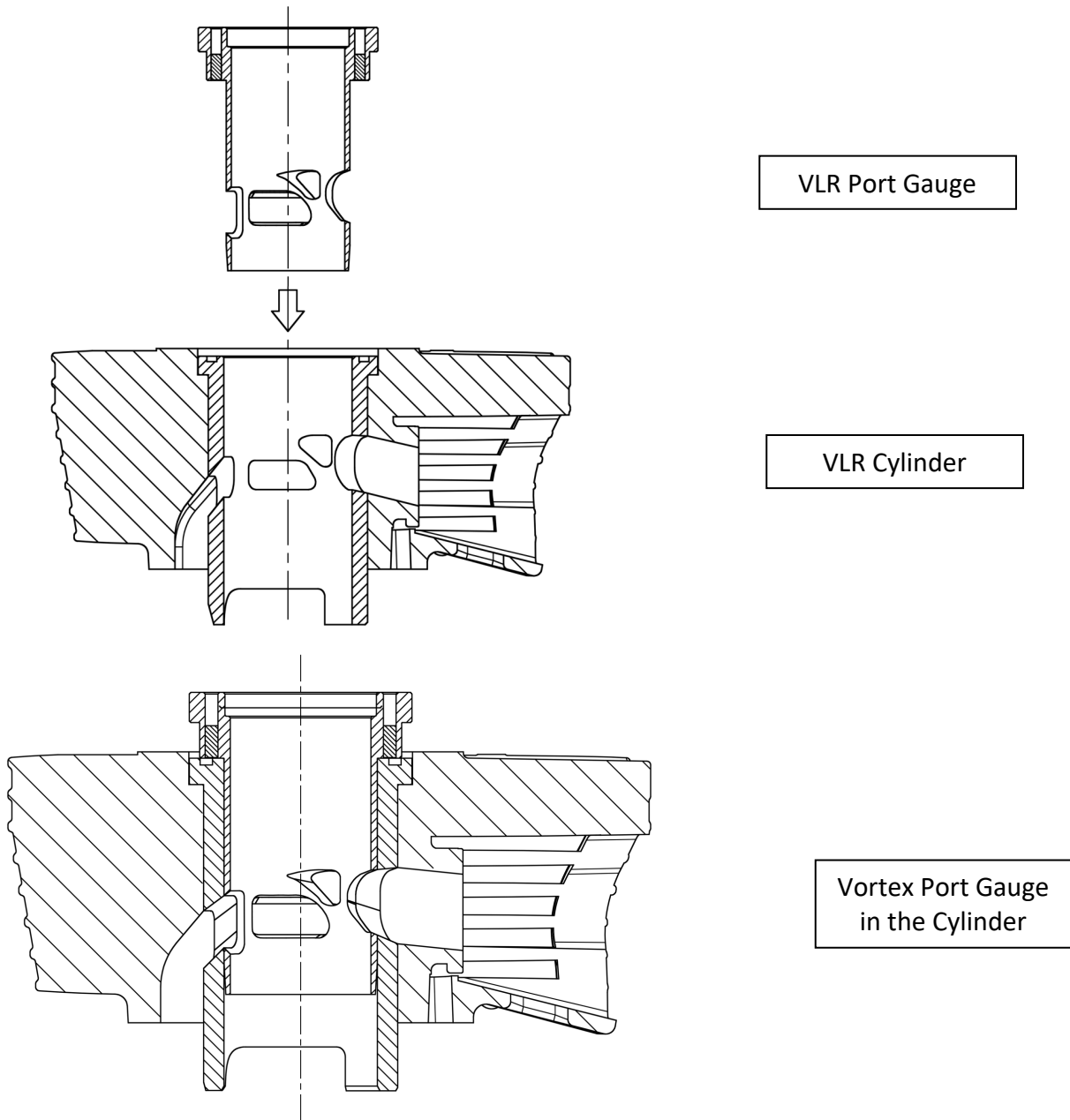

By inserting the reference port gauge in the cylinder, after having positioned it correctly, the Technical Officer will be able, at the technical scrutineering, to detect any irregularities.